



SHING LING®
星菱牌工業用縫紉機
INDUSTRIAL SEWING MACHINE



SL-2800

縱筒型三針五線雙面飾綳縫機

Feed-up-the-arm 3-needle 5-thread Interlock Machine with
Compact Servo Motor and Automatic Thread Trimmer



使用說明書 Instruction Book



星菱縫機股份有限公司
SHING LING SEWING MACHINE CO., LTD.
CE ISO 9001:2008/CNS 12681



Table of Contents

1.	操作安全規範	Safety Instructions	1-1~1-2
2.	安裝	Installation	2
	桌板安裝	Installing on a Table	2
	桌板標準安裝	Table Top Installation(Standard Installation)	2
	馬達及皮帶	Motor and Belt	3
	車縫速度和皮帶輪旋轉的方向	Sewing Speed and Pulley Rotational Direction	3
	離合器馬達	Clutch Motor	3
	皮帶安裝	Handing the Belt	4
	皮帶蓋安裝	Belt Cover Installation	5
	護目鏡及護手罩的安裝	Eye Guard and Finger Guard Installation	6
	輔助蓋的安裝	Supplementary Cover Installation	7
3.	潤滑系統及給油	Lubrication and Oil	8
	潤滑油	Lubrication Oil	8
	給油	Lubricating	8
	當第一次使用機器時	When Using a Sewing Machine for the First Time	8
	檢查油量	Checking Oil Level	8
4.	適當的操作	Proper Operation	9
	拆裝及安裝前蓋	Removing and Resetting the Cylinder Front Cover	9
	如何拆卸	How to Remove	9
	如何安裝	How to Rest	9
	針的規格	Needle System	9
	針的安裝	Needle Installation	9
	穿線	Threading	10
	鬆緊度調整機構	Tension Adjustment at the Tension Unit	11
	押腳的壓力調整	Presser Foot Pressure Adjustment	11
	差動的調整	Differential Feed Adjustment	11
	粗細針的調整	Stitch Length Adjustment	12
	改變粗細針	Changing Stitch Length	12
	裝置	SP Device SP	13
	使用前的檢查	Checks Before Use	13
	使用導布裝置	Using the Fabric Edge Guides	14
	下擺器	For Hemming	14
	倒骨	For Tip Over Covering Seam	14
	立骨	For Covering Seam	14
5.	工作結束清潔	At the End of Work	15
6.	檢查及維修	Checks and Maintenance	16
	針線鬆緊度調整	Needle Thread Tension Adjustment	16
	前過線調整	Needle Thread Eyelet (Front) Adjustment	16
	線圈大小的調整	Needle Thread Strike-off Pin Adjustment	16
	線圈固定片的調整	Holder Adjustment	16
	上飾線鬆緊調整	Top Cover Thread Tension Adjustment	17
	下勾針線鬆緊調整	Looper Thread Tension Adjustment	17
	針線過線調整	Thread Take-up Eyelet Adjustment	17
	下勾針線提線輪調整	Looper Thread Take-up Adjustment	17
	針及上勾針的調整	Needle and Spreader Adjustment	18
	上勾針的調整	Spreader Adjustment	18
	上飾線導桿調整	Top Cover Thread Guide Adjustment	19
	上飾線過線調整	Top Cover Thread Eyelet Adjustment	19
	針及下勾針的調整	Needle and Looper Adjustment	20
	下勾針的距離調整	Looper's Distance Adjustment	20
	下勾針角度及高度的調整	Looper Angle and Height Adjustment	20
	下勾針前後位置的調整	Looper Front-and-Rear Position Adjustment	20
	針高度的調整	Needle Height Adjustment	21

	後頂針片調整	Needle Guard(Rear) Adjustment	22
	後頂針片的高度調整	Needle Guard (Rear) Height Adjustment	22
	後頂針片前後位置的調整	Needle Guard (Rear) Front-and-Rear Position Adjustment	22
	前頂針片調整	Needle Guard (Front) Adjustment	22
	九齒高度的調整	Feed Dog Height Adjustment	23
	標準的位置	Standard Position	23
	調整	Adjustment	23
	押腳位置的調整	Presser Foot Position	23
	拆卸及安裝押腳	Removing and Resetting Presser Foot	24
	如何拆卸	How to Remove	24
	如何安裝	How to Reset	24
	更換潤滑油	Changing the Oil	25
	更換油的時間	Oil Changing Interval	25
	如何更換	How to Change	26
	檢查濾油器及更換	Oil Filter Check and Replacement	26
	如何檢查及更換	How to Check and Replace	26
7.	故障排除	Troubleshooting	27
8.	規格	Specifications	28
9.	針定位說明	Needle up and Down Position	29
10.	穿線圖	Threading	30
11.	縫目長度調整	Proper operation	31
12.	踏板操作	Pedal Operation	32
13.	切線操作說明	Thread Trimming	33~45

1. 確保安全使用

To ensure safe use

請詳閱以下事項安全規範並正確使用此縫紉機及相關設備
Always observe the following instructions to ensure the safe use of the industrial sewing machines and devices.

1-1 機器的應用

Application and purpose

此工業用縫紉機是高品質、高產量縫紉設備，不能修改作其他用途。

The sewing machine is designed to improve productivity in the sewing industry and must not be used for other applications and purposes. Do not use this sewing machine until it can be confirmed that safety measures for the drive units have been taken.

1-2 使用前務必參照使用說明書後再開始使用機器

Before use

Read all instruction manuals thoroughly before starting the use of this machine and follow them. Also, read the instruction manual for the installed drive unit.

1-3 工作環境

Working environment

請避免機器在以下環境使用

DO NOT WORK IN THE FOLLOWING ENVIRONMENTS:

- 高溫及潮濕的地方
Place where atmosphere temperature and humidity give a bad influence the performance of sewing machines.
- 室外或暴露在陽光直射的地方
Outdoors and place where the sewing machines are exposed to sunlight directly.
- 有灰塵、腐蝕氣體或易燃物的地方
Atmosphere containing dust, corrosive gases or flammable gases.
- 額定電壓超過±10%的地方
Place where voltage fluctuation exceeds ±10% of the rated voltage.
- 與馬達消耗功率，電源不符合的地方
Place where power capacity necessary for the used motor specifications cannot be secured.
- 在電流或磁場過強的地方
Place where strong electric or magnetic fields are generated such as near large-output high frequency transmitters or high frequency welding machines.

1-4 拆箱及運送方式

Unpacking and transportation

- (1) 要從車頭上方拆箱
Unpack from the top.
- (2) 當取出機器時，請勿抓握針或針穿線處。
Never hold the parts near the needle or threading parts when removing the sewing machine head from the buffer of box.
- (3) 請至少一人協助搬運機器
When carrying the sewing machine head, have an assistant.
- (4) 當使用手推車搬運機器時，要避免碰撞及震動造成機器損壞
Pay attention not to get excessive impact or shock when moving the sewing machine head with a pushcart.

2. 安裝及準備

Installation and preparation

2-1 安裝及訓練

Instruction and training

非經過專業訓練人員，請勿操作或維修此機器

Operator and workers, who supervise, repair or maintain the machine head and machine unit are required to have the adequate knowledge and operation skills to do the job safely. In order to establish such necessary conditions, it needs for the employer to plan and enforce the safety education and training to those workers.

2-2 車板及馬達

Sewing table and motor

- (1) 請使用堅固的桌板安裝此機器
Prepare a machine table that has enough strength to withstand the weight of the sewing head and any reaction while operating.
- (2) 機器操作時光線要充足。確保操作空間順暢、舒適。
Maintain a comfortable working environment with considering the lighting and the arrangement of sewing machine so that the operators can work smoothly.
- (3) 馬達控制箱要安裝在操作員易於操作的位置
When installing the control box and the related parts on the sewing machines, take care about the posture of the worker.
- (4) 附屬驅動元件及配備要依照安裝手冊正確安裝
Install the drive unit correctly according to the instruction manual.

2.3 接電

Wiring

- (1) 在沒有完全安裝好機器之前，請勿接電
Never connect the plug for power supply until assembly is finished.
- (2) 所有電源接頭要牢固地連接到機器、馬達及其他電氣設備
Fix the connectors securely to the sewing machine head, motor, and electric apparatus.
- (3) 接頭的電線要與符合用電規格
Do not apply excessive force to the connection cords.
- (4) 所有電線要遠離機器運轉的部位
Connect the cords away from the driving parts.
- (5) 接地線要固定在機器上指定的位置
Place the ground wire securely to the designated position on the machine head.

2-4 開始操作機器前

Before operation

- (1) 注意任何潤滑油、矽油，溶濟不要接觸到皮膚或眼睛
Take care not to attach lubricant, silicone oil, and grease on the eyes or skin.
- (2) 機器運轉前檢查是否有注入所需的潤滑油及油量
Be sure to fill or drop lubrication oil before operation the sewing machine.
- (3) 不要把手放在針或機器運轉部位附近
Never put our hand under the needle or near the moving parts of the machine when turning on power supply switch.
- (4) 確認皮帶輪及手輪運轉方向與標示方向相符
When operation a new sewing machine, make sure the rotating direction of pulley agrees with the rotating-direction mark.

2-5 操作機器的時候

During operation

- (1) 確認所有運轉部位的安全蓋都有裝上，如皮帶蓋、護手蓋或護目鏡。
Be sure to operate the sewing machine with the safeguards such as belt cover, finger guard, and eye guard.
- (2) 不要把手指、頭髮或身體靠近機器的針或運轉的部位
Never place the finger, hair or objects under the needle or close to the moving parts while operating the sewing machine.
- (3) 穿線或更換針時務必關閉電源
Be sure to turn off the power supply switch when threading or replacing the needles.
- (4) 不要把手放在上下切線刀組接近刀口的位置
Never place your hands close to the knives when operating the sewing machine with the trimming devices.
- (5) 離開工作崗位或工作完成時，務必再次確認機器電源已關閉
Be sure to turn off the power supply switch when terminating the sewing work or leaving the sewing machine.
- (6) 假如機器操作時有不正常的音響及異味產生，請立即關閉電源
If the sewing machine malfunctions, abnormal sound or smell something unusual while operation, be sure to turn off the power supply switch.

2-6 拆卸或更換零件

Removal

- (1) 更換零件或調整機器前務必關閉電源
Turn off the power supply switch if removed or replaced any parts or during adjustment of sewing machine.
- (2) 電源線從插座拔下時，不可拉線，要從插頭拔下
Do not pull the cord when removing the plug. Be sure to hold the plug itself.
- (3) 控制箱內電壓高，請在關閉電源5分鐘後再打開箱蓋
A high voltage is applied inside the control box. Turn off the power supply switch and wait more than 5 minutes before the cover.

3. 檢查及維修

Maintenance, inspection, and repair

- (1) 請參照機器使用說明作檢查及維修
Follow the instruction manuals for maintenance, inspection, and repair.
- (2) 專業人員需有資格方能作檢查及維修
Entrust the maintenance, inspection, and repair to specially trained personnel.
- (3) 務必關閉電源等到馬達完全停止運轉後才可維修機器
Be sure to turn off the power supply switch and make sure that the sewing machine and motor completely stop before the maintenance, inspection, and repair, (If using a clutch motor, take care that the motor keeps turning for a while even after turning off the power supply switch.)
- (4) 不要依客戶的單方判斷或要求任意更改機器
Do not modify the sewing machine by the customer's judgment.
- (5) 請指名使用原廠商零件作機器維修及更換
Be sure to use original replacement parts for repairs or maintenance.

2. 安裝 Installation



注意 CAUTION

在機器尚未完全安裝前，請勿開啟電源，以免發生危險。
Do not plug the motor's power cable into an electrical outlet until all installation work has been completed. If power is activated prematurely, you may be entangled in mechanisms and injured.

2.1 安裝桌板 Installing on a Table



注意 CAUTION

此機器重達65公斤，請兩人或以上協助拆箱，搬運及安裝的工作。
The sewing machine weights 65 kg or more. Work in twos or more when unpacking, carrying and installing the machine.

2.1.1 安裝桌板 (標準安裝)

Table Top Installation (Standard Installation)

請依照圖示 004, 005和006正確安裝機器

Install the sewing machine correctly as shown in Figs. 004, 005 and 006.

(1) 前組: 請把螺絲及螺帽2組鎖到桌板上。

後組: 請把2組螺栓, 通過橡膠膠墊, 鎖住固定座底面, 防止縫紉機翻倒。

Front set: Please fasten the two sets of screws and nuts on the table of the machine.

Rear set: To prevent the falling of the machine, please securely fasten the two bolts through the rubber mattress to the bottom of the bracket.

(2) 把防震膠墊固定在螺栓上

Cover the bolts with the rubber cushions.

(3) 把機器放在已固定的四個防震膠墊上面

Set the sewing machine over the rubber cushions.

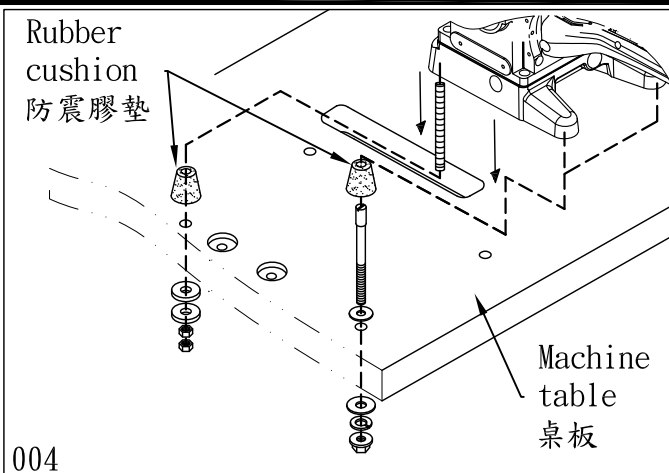

004

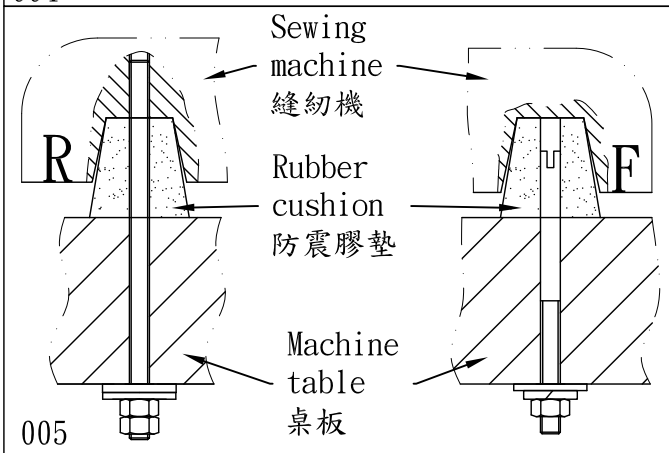

005

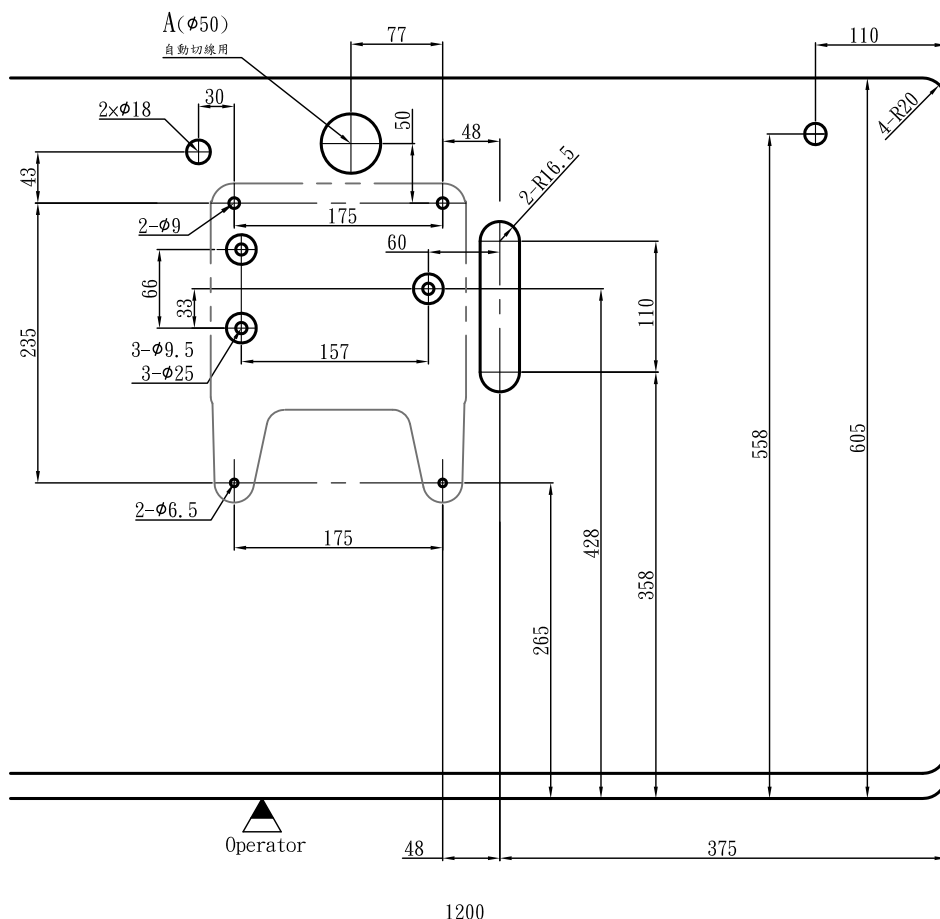

2.2 馬達及皮帶 Motor and Belt

2.2.1 機器轉速及皮帶輪旋轉的方向

Sewing Speed and Pulley Rotational Direction

- ◇ 最高轉速為4500轉(間歇的操作)。機器開始使用200小時內(大約一個月)，請設定低於最高轉速約15%到20%的轉速以確保機器更長久使用。

The maximum speed of this sewing machine is 4500 rpm (in intermittent operation). When using it for the first time, using it at anywhere from 15% to 20% lower than the maximum speed for the first 200 hours (approx. 1 month) keeps the machine in good condition and enables longer lasting use.

Japanese standard 日本標準	8	9	10	11	12	13	14
Metric standard 公制標準	60	65	70	75	80	85	90

- ◇ 馬達②和機器的皮帶輪①都是順時鐘旋轉 (圖007)

Both the motor pulley ② and the machine pulley ① rotate in the clockwise direction.

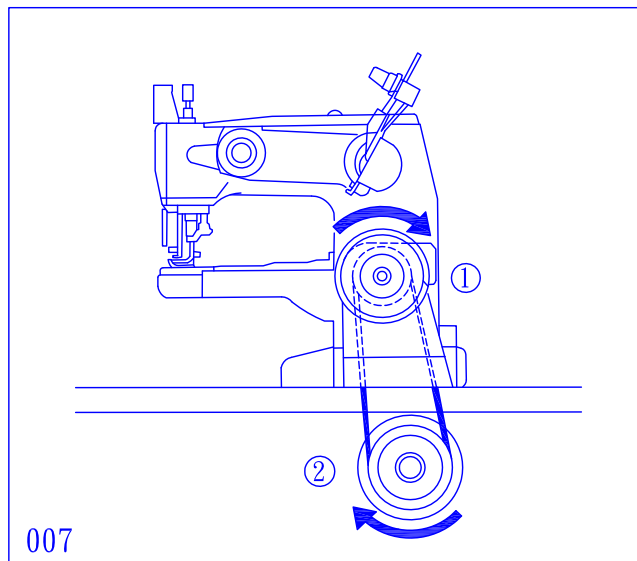

注意 CAUTION

假使皮帶輪逆時鐘旋轉，或油沒有適當使用，可能會造成機器的故障。

If the pulleys rotate backwards, oil is not being properly supplied to parts resulting in sewing machine break-down.

2.2.2 離合器馬達

Clutch Motor

- ◇ 請參閱您所使用馬達的操作指南 (圖 008)
See the instruction manual of the motor you are using.
- ◇ 離合器馬達正確的位置是馬達皮帶輪②的中心點和機器皮帶輪①的中心點對齊。當踩腳踏板時，馬達皮帶輪②應向左移動。

The clutch motor should be installed in a position where the center of the motor pulley ② and the center of the machine pulley ① align with one another when the pedal is depressed and the motor pulley ② moves to the left.

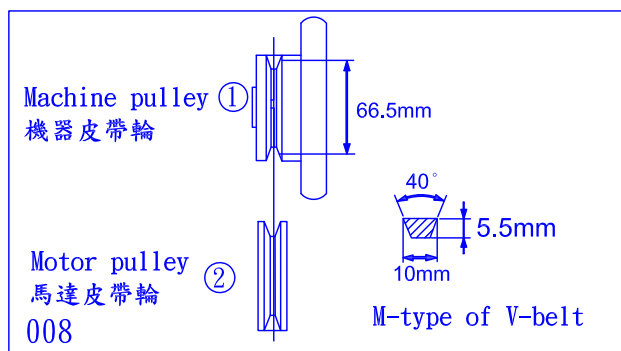

注意 CAUTION

不當使用太大尺寸的皮帶輪可能使機器轉速過快，造成故障。
Use of an inappropriate motor pulley may cause the sewing machine to exceed the maximum speed whereby resulting in breakdown.

2.3 裝上皮帶 Hanging the Belt



注意 CAUTION

關閉馬達電源並確認已停止運轉後再裝皮帶以確保安全。
Shut off power to the motor and check motor rotation has stopped before hanging or replacing the belt. If power is on, hands or clothing may become entangled whereby resulting in injury.

- (1) 把皮帶①裝到機器皮帶輪②上。
Hang the belt① around the machine pulley ②.
- (2) 旋轉機器皮帶輪②使皮帶①順利裝到馬達皮帶輪③上。(圖 009)
While turning the machine pulley ②, hang the belt① around the motor pulley ③.
- (3) 加壓約 1.02 kg f 的力量到皮帶的中心點，使皮帶有10-20mm的彎曲鬆緊度。
Stretch the belt so that the belt flexes 10-20mm when a force of about 10N(1.02kgf) is applied to the center of the belt
- (4) 調整好後，請鎖緊馬達上下導桿的螺絲。(圖 010)
Once the belt is sufficiently taut, securely lock the motor pulley.
* How the motor is locked down differs depending on motor, therefore see the instruction manual of the motor.

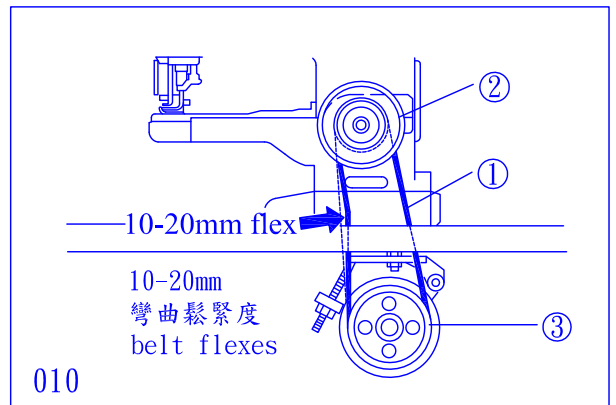
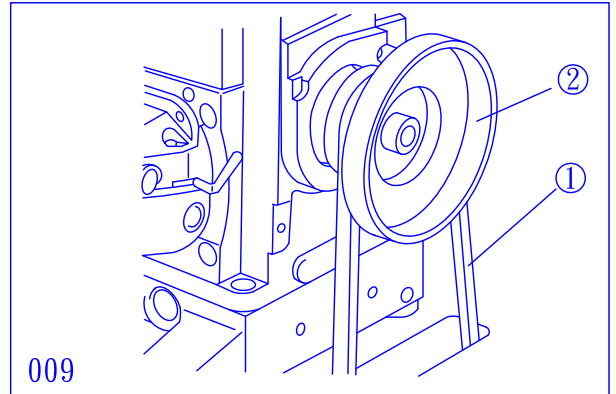

2.4 皮帶蓋的安裝 Belt Cover Installation

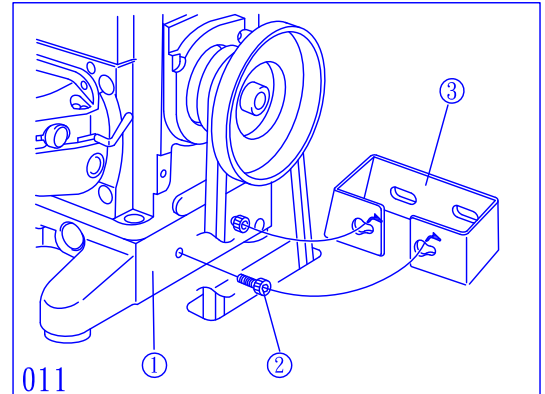

- (1) 把螺絲②鎖進油槽底座①約1/2螺絲長度的距離。
Insert the screws② halfway into the oil reservoir①.
- (2) 固定輔助蓋③到螺絲①上面然後鎖緊螺絲。
Fit the holes on the supplementary belt cover③ over the heads of the screws②, slide the cover to the rear and tighten the screws②.

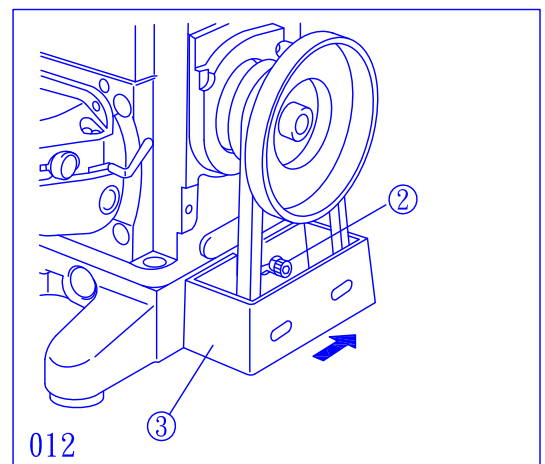

- (3) 用螺絲⑤把下蓋④鎖上去。
Attach the belt cover (lower)④ to the sewing machine with the screws⑤.

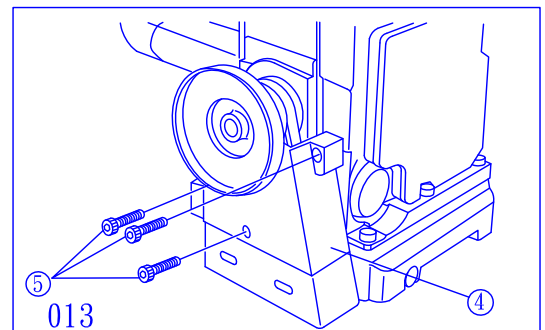

- (4) 再把上蓋⑥用螺絲⑦鎖在下蓋④上面。
Fit the belt cover (upper)⑥ onto the belt cover (lower)④ and lock in place with the screws⑦.

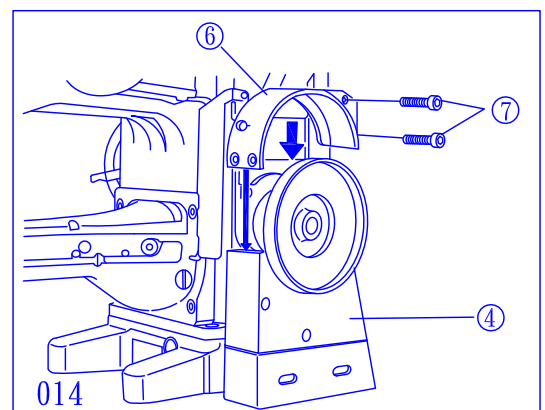

2.5 護目鏡及護手罩安裝

Eye Guard and Finger Guard Installation



注意 CAUTION

務必使用護目鏡^⑧和護手蓋^⑨以確保工作安全

Use the sewing machine with the eye guard ^⑧ and the finger guard ^⑨ attached. Also, lower the eye guard ^⑧ to the set position when working.

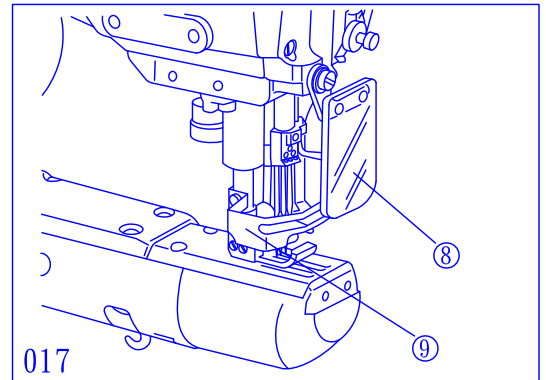

2.7 拷下擺布板的安裝 Supplementary Cover Installation

把布板①用螺絲③鎖到前蓋上導布器②和拷下擺檔邊④和⑤用螺絲⑥⑦和墊片⑧鎖上

Attach the supplementary cover① to the cylinder front cover ② with the screws③.

* The fabric edge guides ④ ⑤ can be attached to the supplementary cover ① with the screws ⑥ ⑦ and the washers⑧.

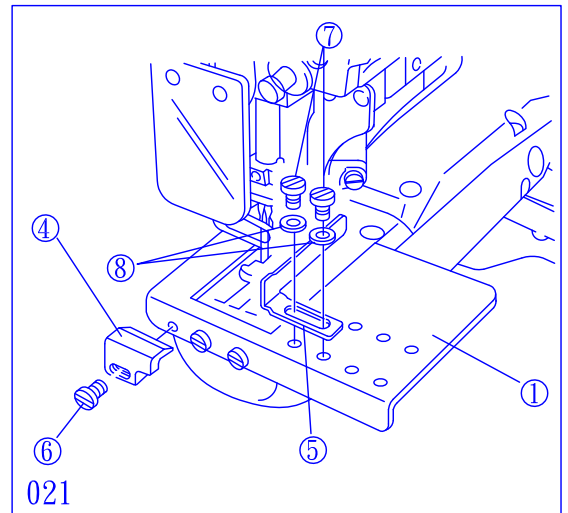
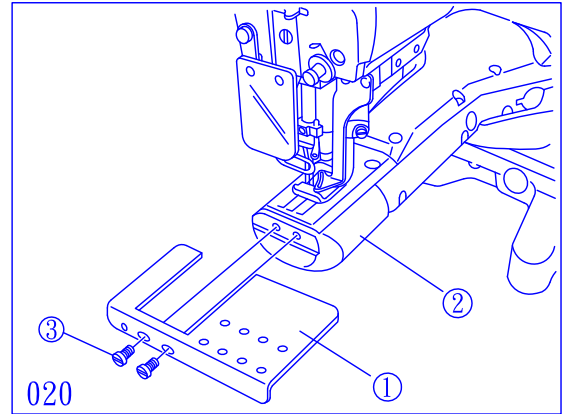

3. 潤滑系統及給油 Lubrication and Oil

3.1 潤滑油 Lubricating Oil



注意 CAUTION

不要使用指定油以外的添加物而讓油的損壞造成機器的故障。
Do not use oil additives as they can deteriorate the oil resulting in sewing machine breakdown.

- ◇請使用原廠提供或同等級的用油
Lubricating oil : CPC SPINDLE OIL R22 or equivalent
- ◇油槽的容量約600 C. C.
Capacity of oil reservoir : 600 cc

3.2 給油方式 Lubricating

3.2.1 當第一次使用機器時，打開油鏡③把油注入油槽，油量請勿超過上線②。

When Using a Sewing Machine for the First Time
A sewing machine is shipped with the oil drained. Before using a sewing machine for the first time, charge with oil. To add oil, remove the oil sight window ③ labeled "OIL" and add oil up to the top line on the oil gauge ②.

3.2.2 打開電源啟動機器，查看油鏡是否有油打上來，如果沒有，請檢查濾油器，必要時請更換新的濾油器，(更換濾油器請參閱26頁)
After starting the sewing machine, check oil is coming from the nozzle looking from the oil sight window. If oil is not coming out, check and replace the oil filter (How to change oil filter, see page. 26).

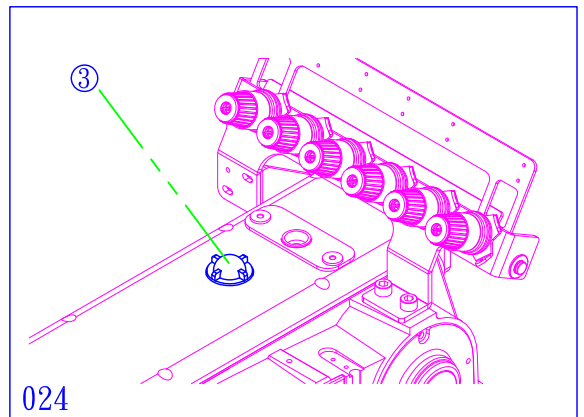
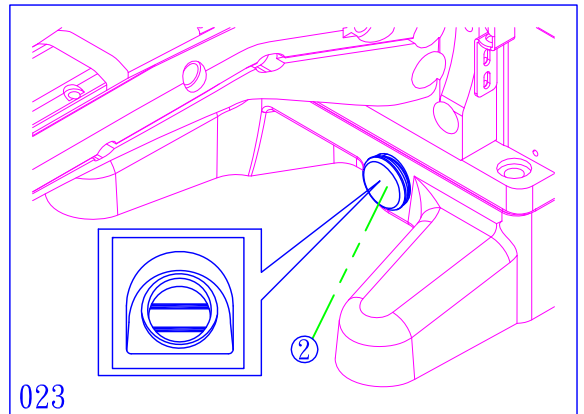

注意 CAUTION

假如油嘴噴油量太少,油有泡泡現象產生,請檢查油量,必要時請更換新的濾油器。
If very little oil is sprayed from the nozzle despite a sufficient charge of oil or if there are many bubbles in the oil, check and replace the oil filter.

4. 適當的操作 Proper Operation

4.1 拆卸及安裝前蓋

Removing and Resetting the cylinder Front Cover

如何拆卸

How to Remove

握住前蓋下緣，往後拉出。

Slide the cylinder front cover ① towards the front of the sewing machine and off.

如何安裝

How to Reset

使前蓋兩孔與針板下方兩個固定梢對齊裝入，可聽到" 咔嚓" 聲表示有裝妥。

Align the cylinder front cover ① with the pins and slide it onto the sewing machine until hearing it catch.

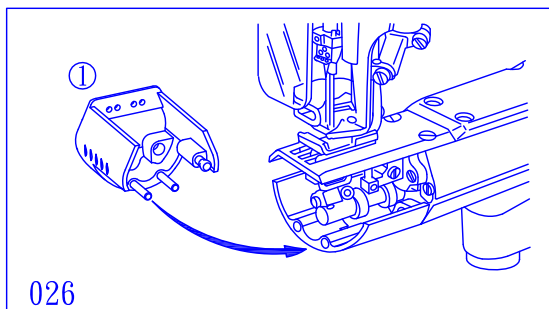
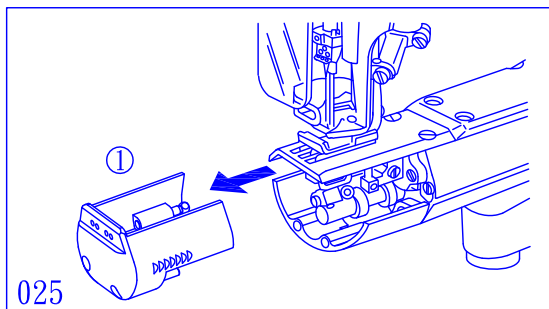

注意 CAUTION

工作時前蓋務必裝上,以確保安全.

Set the cylinder front cover ① on when sewing for safety use.

4.2 針的規格 Needle System

此機器使用 TVx7 GAS 針

This sewing machine uses TVx7 GAS needles.

There are many sizes of needle, therefore select a needle that is suited for the type and thickness of fabric being sewn.

4.3 針的安裝 Needle Installation



注意 CAUTION

安裝針之前請關閉電源，以確保安全。

Shut off power before installation the needle.

- (1) 鬆開螺絲 ③ 用螺絲起子把針 ② 鎖到針榴孔的頂點。
Loosen the screws ③ that lock the needles ② in place with a screwdriver.
- (2) 針的溝槽中心要與針榴孔中心對齊。
Insert a new needle with facing its scarf to the right back to the end of the hole of the needle clamp ④, with tweezers
- (3) 鎖緊螺絲 ③ 使針 ② 固定在正確位置。
Tighten the screws ③ to lock the needles ② in place.

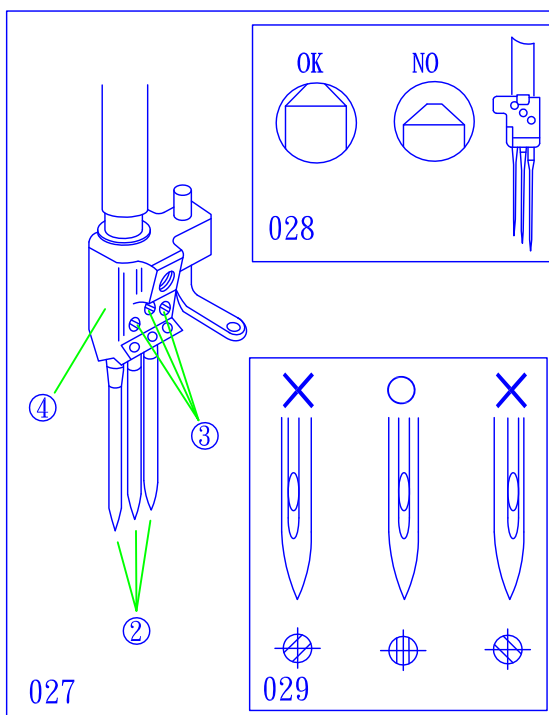

註解 Notes

- 注意使用6 k9f的扭力鎖上螺絲 ③
Use 0.6 N·m(6 kgf·cm) of torque to tighten the screws ③
- 換新針後要檢查車針與下勾針及頂針片間隙是否正確。
After replacing a needle, check the clearance between the needle and looper, and between the needle and needle guards(see pg.21 and 23).

4.4 穿線 Threading

(A: 針線)

(A: Needle threads)

把線頭拉到針的前面，線頭切平整後再穿線。

Pull the thread knots to front of needles, cut the knots off and rethread through the needles.

(B: 上飾線)

(B: Top cover thread)

如圖把線頭穿過上飾線過線桿。

Pull the thread until the knot comes out.

(C: 下勾針線)

(C: Looper thread)

把線頭穿過後，線頭切平整後穿入下勾針針孔。

Pull the thread until the knot comes out, then cut the end with scissors.

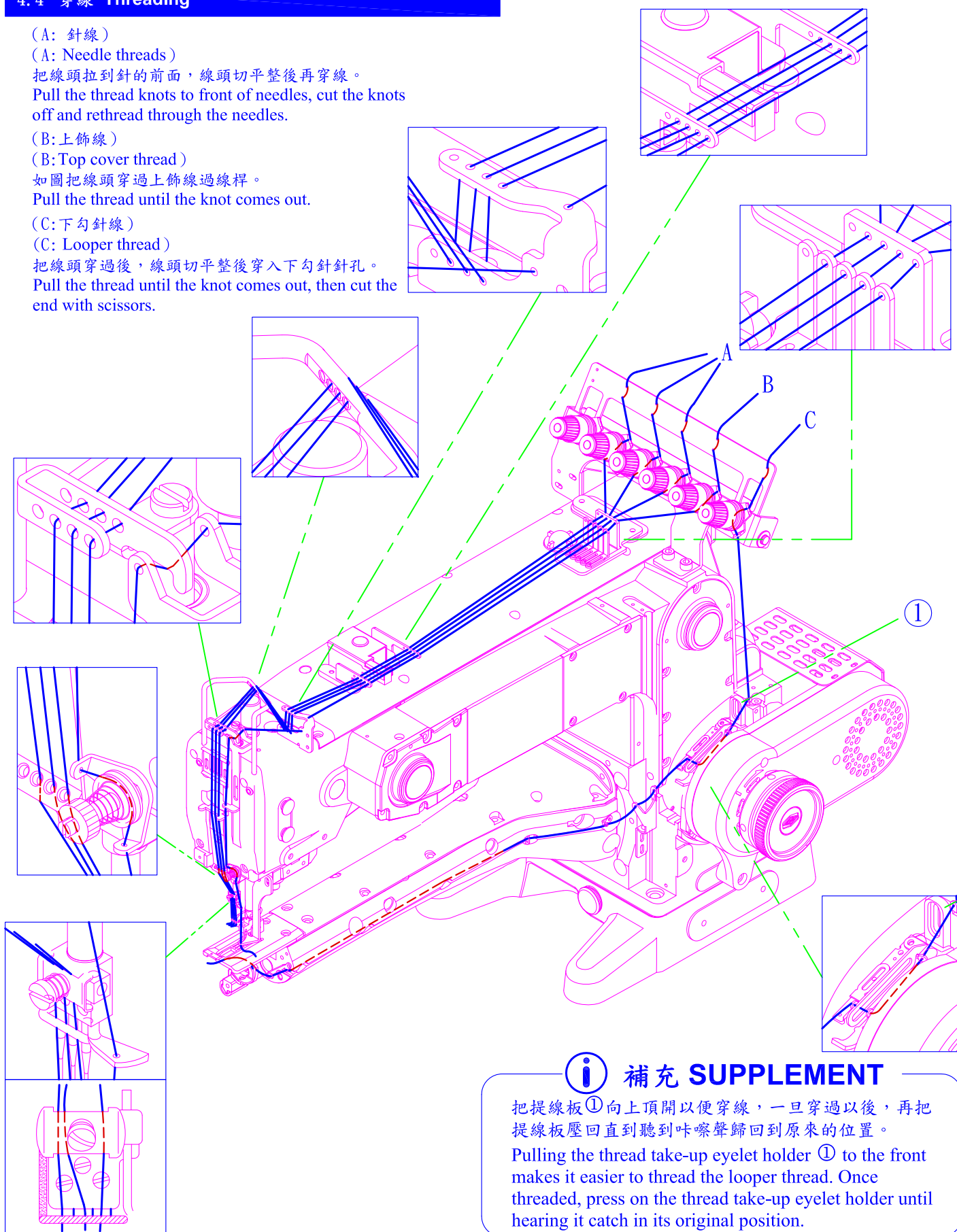

i 補充 SUPPLEMENT

把提線板①向上頂開以便穿線，一旦穿過以後，再把提線板壓回直到聽到咔嚓聲歸回到原來的位置。

Pulling the thread take-up eyelet holder ① to the front makes it easier to thread the looper thread. Once threaded, press on the thread take-up eyelet holder until hearing it catch in its original position.

4.5 鬆線裝置的調整 Tension Adjustment at the Tension Unit

線的鬆緊度調整依照不同布樣的材質、線材、縫目寬度、粗細針等因素有所不同。

Thread tension varies depending on the type of fabric, type of thread, stitch width, stitch length and conditions of use. Adjust thread tension from the individual thread tension spring caps.

- 往順時鐘方向旋轉調整鈕，可使線變緊
To tighten the thread tension, turn the caps clockwise.
- 往逆時鐘方向旋轉調整鈕，可使線變鬆
To loosen the thread tension, turn the caps counterclockwise.

- | | |
|-------------------------------|------------------------------|
| ① 四針用
4-Needle Use | ④ 右針線
Right needle thread |
| ② 左針線
Left needle thread | ⑤ 上飾線
Top cover thread |
| ③ 中針線
Middle needle thread | ⑥ 下勾針線
Looper thread |

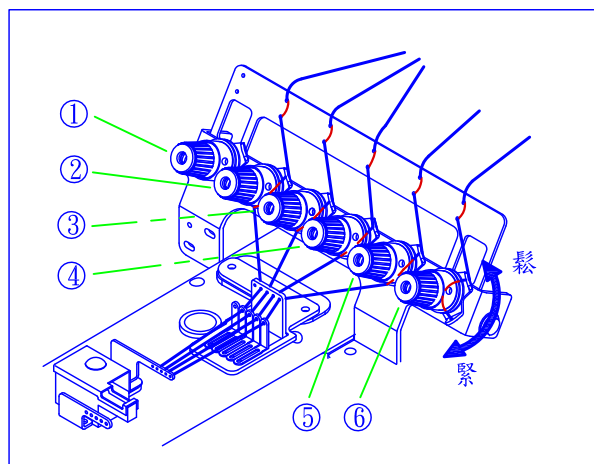

4.6 押腳壓力的調整 Presser Foot Pressure Adjustment

調整適當押腳壓力使車縫縫目美觀穩定。

Relieve presser foot pressure as much as possible within a range that keeps the stitch stable.

- (1) 鬆開螺母⑧並旋轉壓力鈕⑦
Loosen the lock nut⑧ and turn the presser spring regulator⑦.
 - 順時鐘方向，壓力增加
To increase the pressure, turn the regulator clockwise.
 - 逆時鐘方向，壓力減少
To decrease the pressure, turn the regulator counterclockwise.
- (2) 當壓力調好以後，請鎖緊螺母⑧。
Once pressure has been adjusted, tighten the lock nut⑧.

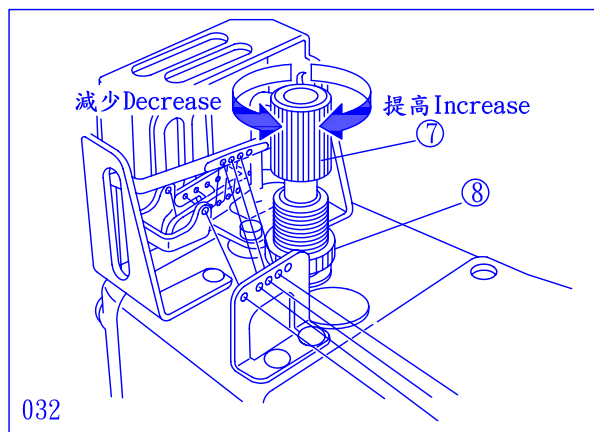

4.7 差動的調整 Differential Feed Adjustment

- (1) 鬆開螺母⑨
Loosen the lock nut⑨.
 - (2) 以差動曲柄調整差動比⑩
Adjust differential feed with the differential lever⑩.
 - 曲柄調上，布有收縮的效果
To make gathering, raise the lever.
 - 曲柄調下，布有伸展的效果
To make stretching, lower the lever.
- * 請參照下表一、刻度與差動比的關係
Position the lever as suggested by the relationship of graduations and differential ratio of Table 1.
- (3) 當差動比調好以後，請鎖緊螺母⑨。
Once differential ratio has been adjusted, tighten the lock nut⑨.

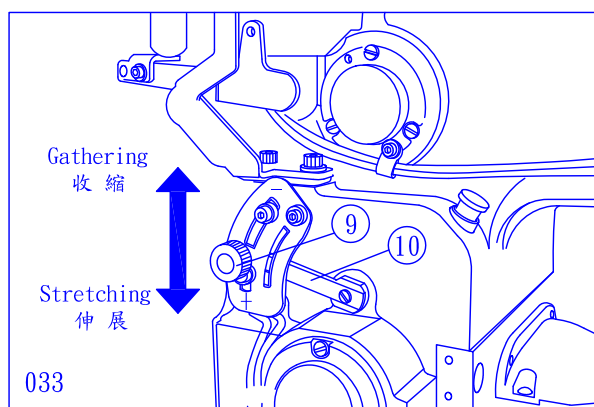

表一 Table 1

刻度 Graduation	差動比 Differential ration	效果 Remarks
S	1:0.8	布會伸展 Stretching
1	1:1	
	1:1.5	縫目長度4mm或以下 Stitch length: 4mm or less
2	1:2	縫目長度3mm或以下 Stitch length: 3mm or less



注意 CAUTION

- 在最粗針4mm的時候，差動比大約為1 : 1.5
The differential ratio at the maximum stitch length of 4 mm is available up to 1:1.5.
- 當差動比調在最大約1 : 2 的時候，粗細針長度約為3 mm或更少
At the maximum differential ratio of 1:2, the stitch length is 3 mm or less.

4.8 粗細針的調整 Stitch Length Adjustment

粗細針可以在1.2 mm 到 4 mm範圍內調整任何尺寸。

Stitch length can be adjusted infinitely from 1.2 mm to 4.0 mm.

手輪上面每一個刻度表示粗細針長度(以mm為單位)

Each graduation on the pulley indicates a stitch length in mm.

*實際粗細針長度依照布料的厚度和差動比有所不同

The actual length of the stitch will vary depending on the type and thickness of fabric, and differential ratio.

改變粗細針

Changing Stitch Length

(1)用左手壓按鈕①到底使按鈕底端接觸到內部零件

Press the pushbutton ① with your left hand until feeling the button tip contact the internal part.

(2)仍然壓住按鈕①並用右手旋轉手輪③向前

With the pushbutton ① still depressed, turn the machine pulley to the front with your right hand. The pushbutton ① draws inward, therefore press the pushbutton ① forcefully.

●旋轉手輪③順時針方向，可車縫粗針

To make the stitch length larger, turn the pulley clockwise.

●旋轉手輪③逆時針方向，可車縫細針

To make the stitch length smaller, turn the pulley counterclockwise.

(3)仍然壓住按鈕①並用右手旋轉手輪③使上面的記號與皮帶蓋的記號對齊

With the pushbutton ① still depressed, align the scale marking of the machine pulley ③ with the mark ② on the mark of the belt cover.

(4)當記號對其後，鬆開按鈕①

Once the markings have been aligned, release the pushbutton ①

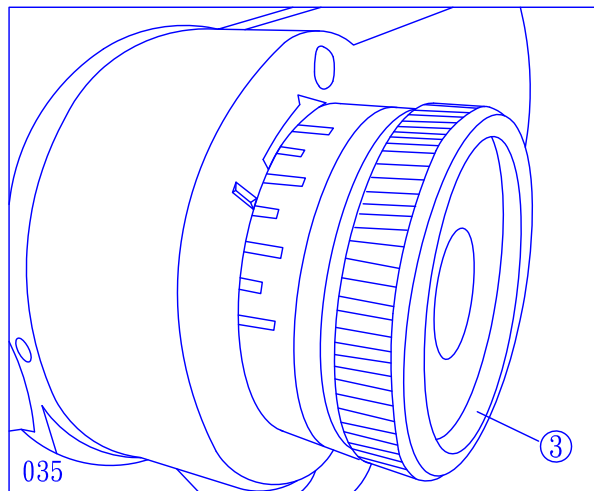
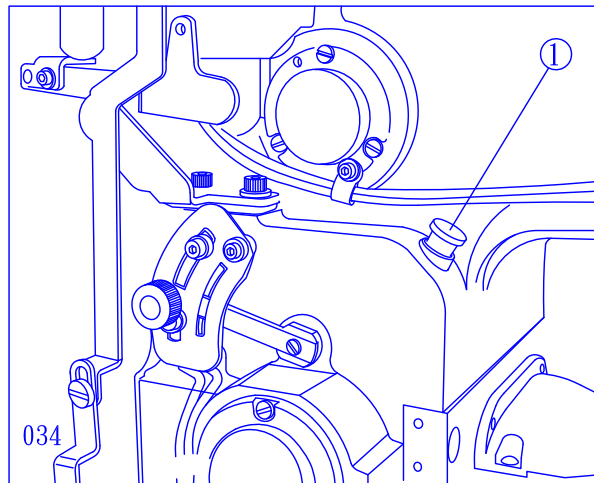

注意 CAUTION

檢查按鈕①要完成後回到原來位置並且手輪能很平順的轉動。

Check that the pushbutton returns completely to the released position and that the machine pulley rotates smoothly.

4.9 SP矽油盒 SP Device

為了避免機器在高速車縫造成斷線或跳針或使用合成纖維線或布料時，請使用矽油盒。

To prevent thread breakage and skip stitch in high speed sewing or when using synthetic thread or fabric, use the SP device.
The device uses (dimethyl) silicon oil.

使用前檢查
Checks Before Use

打開矽油盒①上的油封②並檢查矽油量如果油量不夠，請補充矽油。
Remove the seal plug ② from the SP container ① and check there is (dimethyl) silicon oil. If oil level is low, add (dimethyl) silicon oil.

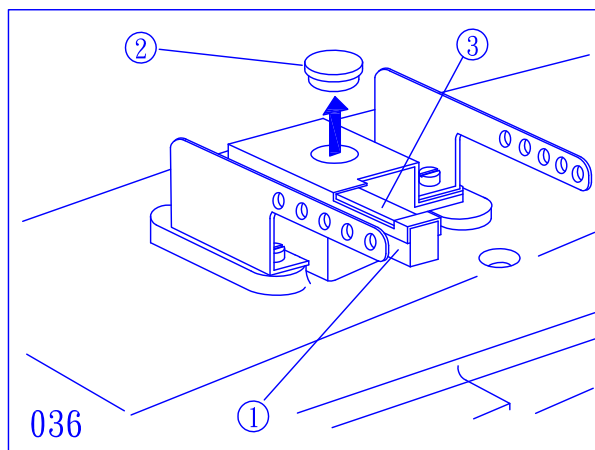

注意 CAUTION

● 如果沒有使用矽油盒，請移除油氈③以免造成不良的車縫效果。

If not using the SP device, remove the felt ③ from the device.
If left inside, it may adversely affect sewing.

● 因矽油含有乙烷成份，如果機器有接觸到矽油，請立即擦拭乾淨。

If (dimethyl) silicon oil contacts any parts other than the SP device, wipe it off. Adhering (dimethyl) silicon oil can result in sewing machine breakdown.

4.10 使用拷下擺輔助擋邊 Using the Fabric Edge Guides

4.10.1 For Hemming

The fabric edge guide(right)① adjusts the fold width of the fabric.

(1)依車縫下擺的寬度，鬆開螺絲②左右移動擋邊①到適當的位置

Loosen the screws ② and slide the fabric edge guide (right) ① to the left and right until properly positioned.

★如果要車縫更大寬度，可使用螺絲孔③

To greatly reposition the guide, use the other screw holes ③.

(2)鎖緊螺絲②

Tighten the screws ②.

左擋邊④可固定下擺左布邊

The fabric edge guide (left) ④ adjusts the left edge of the folded fabric.

(1)鬆開螺絲⑤並左右移動左擋邊④到適當的位置

Loosen the screw ⑤ and slide the fabric edge guide (left) ④ to the left and right until properly positioned.

(2)鎖緊螺絲⑤

Tighten the screw ⑤.

4.10.2 倒骨作業 For Tip Over Covering Seam

(1)鬆開左右導布器螺絲⑧

Loosen the screws ⑧ of the fabric guide.

(2)放入已包縫的布邊到右導布器⑥和左導布器⑦中間導槽內。

Insert the aligned fabric edges between the fabric guide (right) ⑥ and fabric guide (left) ⑦.

(3)把包縫骨中心與右針中心對準，並且調整右導布器⑥和左導布器⑦的間隙，使布能平順的進料。

Position the seam at the center of the right needle and adjust the clearance between the fabric guide (right) ⑥ and fabric guide (left) ⑦ to feed the fabric smoothly.

(4)調整適當的間隙以後，鎖緊螺絲⑧

Once the clearance has been adjusted, tighten the screws ⑧.



注意 CAUTION

對齊的布邊和左針相關位置因布料有所不同。

The positional relationship of the aligned fabric edges and the left needle varies depending on the piece of the garment.

4.10.3 立骨作業 For Covering Seam

(1)鬆開左右導布器的螺絲⑪

Loosen the screws ⑪ of the fabric guide.

(2)把包縫立骨放在中間針的中心點，調整右導布器⑨和左導布器⑩的間隙，使布能平順的進料。

Spread open the fabric seam, position the seam at the center of the needle width and adjust the clearance between the fabric guide (right) ⑨ and fabric guide (left) ⑩ to feed the fabric smoothly.

(3)調整適當間隙後，鎖緊螺絲⑪

Once the clearance has been adjusted, tighten the screws ⑪.

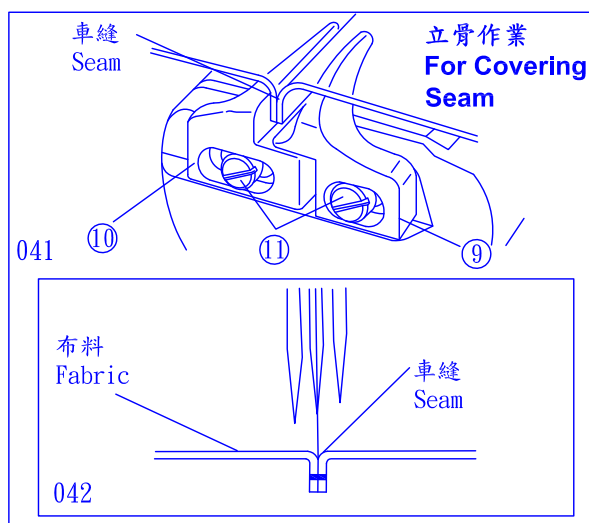
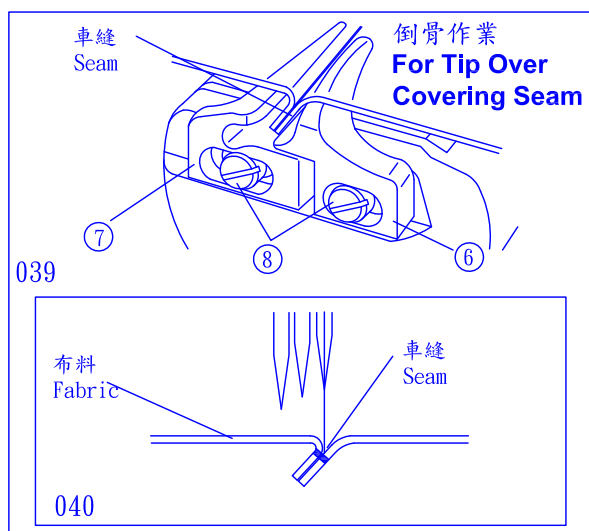
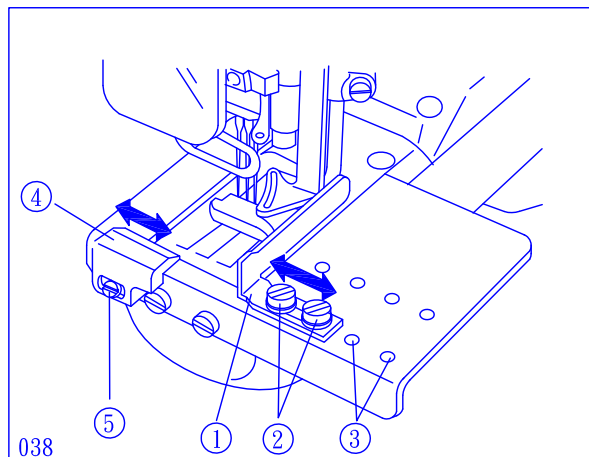

5. 工作結束清潔 At the End of Work

- ◇ 每天工作結束後，打開前蓋，徹底清除堆積在機器上面的灰塵和布屑和線頭。
At the end of work everyday, remove the cylinder front cover and clean away any dust and lint accumulated in the sewing machine.
- ◇ 每星期至少一次打開前蓋，提起押腳把針板及九齒週圍清理乾淨。
Once a week, remove the cylinder front cover and the presser foot, and clean in and around the stitch plate and feed dog.

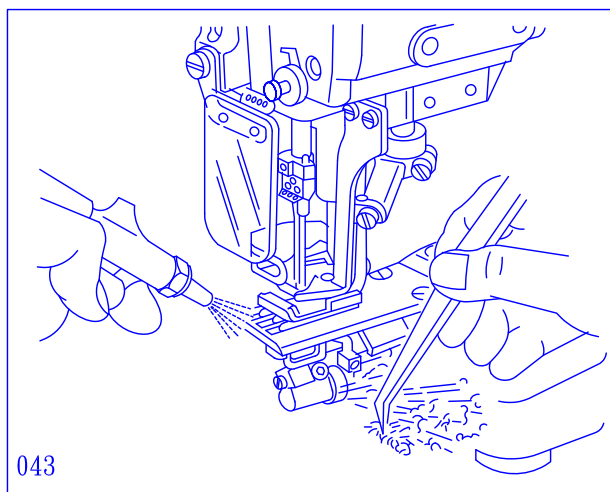

6. 檢查及維修 Checks and Maintenance

6.1 針線張力的調整 Needle Thread Tension Adjustment

6.1.1 針線張力的調整

Needle Thread Eyelet(Front) Adjustment

調整過線桿(前)的高度，調整針線的張力

標準的位置是臂①的上緣和過線桿(前)上緣的距離為40mm

鬆開螺絲②調整過線桿(前)

①調整好以後，鎖緊螺絲②

The tension of the needle threads can be adjusted with the needle thread eyelet (front) ①. In the standard position, the top surface of the arm ① and the top surface of the needle thread eyelet (front) ① is 40 mm apart.

Loosen the screws ② to adjust the needle thread eyelet (front) ①. Once the eyelet has been positioned, tighten the screws ②.

●調低過線桿(前)，可使針線變鬆

To loosen the needle thread, lower the needle thread eyelet (front).

●調高過線桿(前)，可使針線變緊

To tighten the needle thread, raise the needle thread eyelet (front).

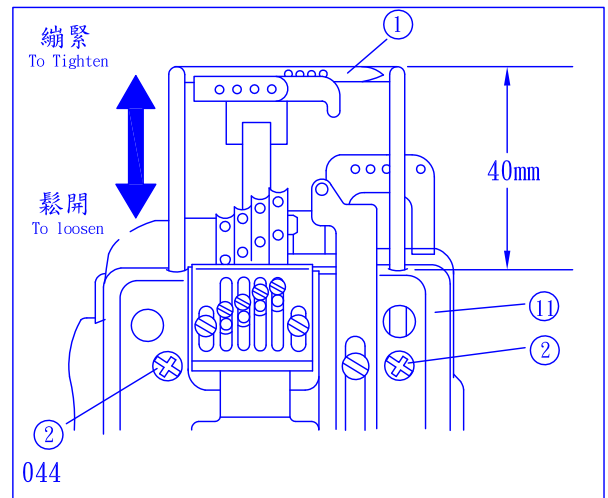

6.1.2 線圈銷的調整 Needle Thread Strike-off Pin Adjustment

線圈柄③④⑤可調整線圈的大小，標準位置是針棒在低點時，針棒過線孔中心點與右針、中針和左針的線圈銷頂點的距離分別為2，3 和4 mm如圖045。

The size of the needle thread loops can be adjusted with the needle thread strike-off pins ③ ④ ⑤. In the standard position, the center of the eye on the needle bar thread eyelet ⑥ and the top edge of needle thread strike-off pins of the right needle, middle needle and left needle are 2,3 and 4 mm apart respectively when the needle bar is at the lowest point. (See Fig. 045.)

鬆開螺絲⑦調整線圈柄③④⑤，一旦調整到正確位置後，請鎖緊螺絲⑦

Loosen the screws ⑦ to adjust the needle thread strike-off pins ③ ④ ⑤.

Once the pins have been positioned, tighten the screws ⑦.

●若線圈要小一點，請降低線圈銷

To make loop smaller, lower the needle thread strike-off pin.

●若線圈要大一點，請升高線圈銷

To make loop larger, raise the needle thread strike-off pin.

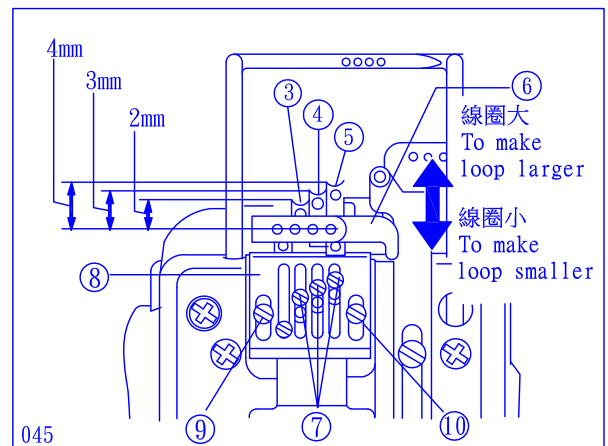

6.1.3 固定片的調整 Holder Adjustment

需要換不同線材時可一併調整固定片⑧的高度來調整針線線圈的大小。

After changing the type of thread, the position of the holder ⑧ can be moved to adjust the size of the loop of the all needle threads.

鬆開螺絲⑨和⑩後，調整固定片⑧的高度，調整到正確位置後，鎖緊螺絲⑨和⑩

Loosen the screws ⑨ ⑩ to adjust the holder ⑧. Once the holder has been positioned, tighten the screws ⑨ ⑩.

●若線圈要小一點，請降低固定片

To make loop smaller, lower the holder.

●若線圈要大一點，請升高固定片

To make loop larger, raise the holder.

6.2 上飾線鬆緊度的調整 Top Cover Thread Tension Adjustment

6.1.1 針線張力的調整

Needle Thread Eyelet(Front) Adjustment

機器直筒背的表面和上飾線揚線孔的距離是20 mm

鬆開螺絲②調整上飾線揚線片①的高度，調整正確高度後，鎖緊螺絲②
In the standard position, the top surface of the arm and the top surface of the top cover thread take-up eyelet ① is 20 mm apart. Loosen the screw ② to adjust the top cover thread take-up eyelet ①. Once the eyelet has been positioned, tighten the screw ②.

- 若要減少上飾線量，請降低揚線片①

To decrease take-up amount, lower the top cover thread take-up eyelet.

- 若要增加上飾線量，請升高揚線片①

To increase take-up amount, raise the top cover thread take-up eyelet.

*若上飾線使用羊毛線或其他彈性線時，請降低揚線片的高度

When using woolly thread or other stretchable thread as the top cover thread, lower the top cover thread take-up eyelet ①.

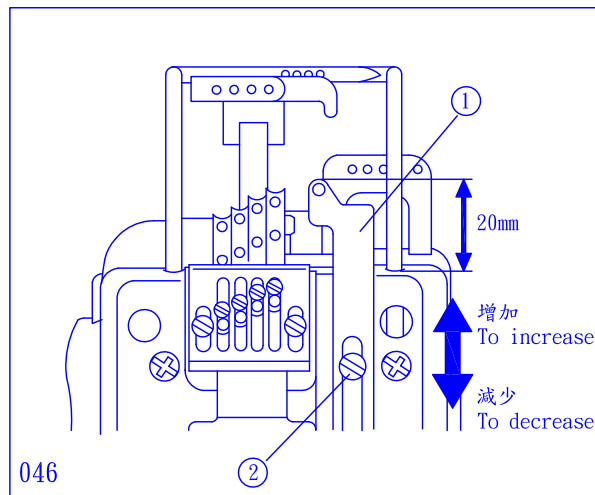

6.3 下勾針線鬆緊度的調整 Looper Thread Tension Adjustment

6.3.1 當螺絲④在下勾針提線板③長孔的中間是正確的位置

鬆開螺絲④調整提線板③調整正確位置後鎖緊螺絲④

Thread Take-up Eyelet Adjustment

The thread take-up eyelet ③ is in the standard position when the screw ④ is at the center of the slot. Loosen the screw ④ to adjust the thread take-up eyelet ③. Once the eyelet has been positioned, tighten the screw ④.

- 若要減少下勾針線量，請升高提線板③

To decrease take-up amount, raise the thread take-up eyelet.

- 若要增加下勾針線量，請升降提線板③

To increase take-up amount, lower the thread take-up eyelet.

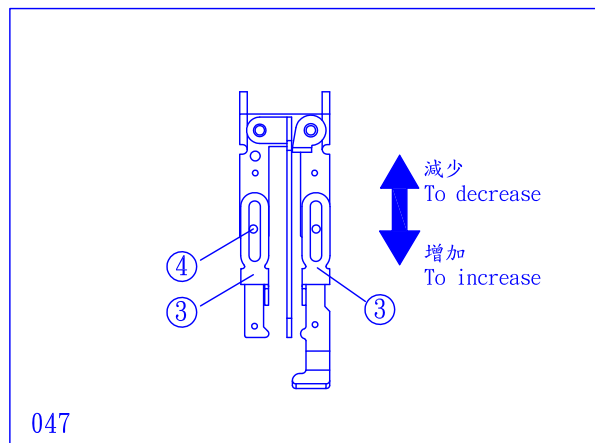

注意 CAUTION

下勾針線量太多會造成跳線

Top much take-up of looper thread can cause skip stitch.

6.3.2 下勾針提線輪的調整

Looper Thread Take-up Adjustment

當針棒在最高點時，調整提線輪⑤在開始要提線的位置。

When the needle bar is at the highest point, move the looper thread take-up ⑤ to a position where the looper starts taking up thread.

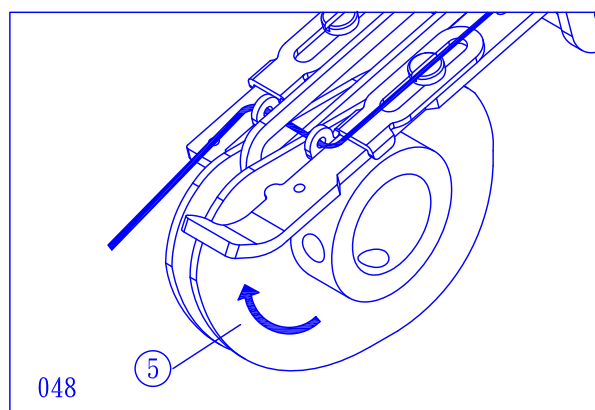

6.4 針及上勾針的調整 Needle and Spreader Adjustment

6.4.1 上勾針的調整

Spreader Adjustment

- (1) 鬆開上勾針的螺絲③和上勾針座的螺絲④(圖049)
Loosen the screw ③ of the spreader and the screw ④ of the spring holder. (See Fig. 049.)
- (2) 調整上勾針①使勾針尖點②與左針邊緣間隙為0.5-0.8 mm (圖050)
Adjust the spreader ① so that the clearance between the left needle and the hook ② of the spreader ① is 0.5-0.8 mm. (See Fig. 050.)
- (3) 移動上勾針①到左死點使勾針尖點與左針中心點的距離為4.5-5.5 mm 然後鎖緊螺絲④(圖049 和 圖050)
Adjust the spreader ① so that the distance from the center of the left needle to the hook ② is 4.5-5.5 mm when the spreader ① is to the farthest left. Then, tighten the screw ④. (See Figs. 049 and 050.)
- (4) 調整上勾針①的下緣與針板表面的距離為11~12 mm (圖051)
Adjust the spreader ① so that the distance from the top surface of the stitch plate to the bottom surface of the spreader ① is 11-12 mm. Then, tighten the screw ③. (See Figs. 049 and 051.)



注意 CAUTION

上勾針①的高度和針的距離要在已調整範圍內才能使上飾線穿過右針的後面與左針交會進而形成上飾線。

Match the height of the spreader ① to the needle distance within the adjustment range, so that the top cover thread passes behind the right needle and is caught by the left needle.

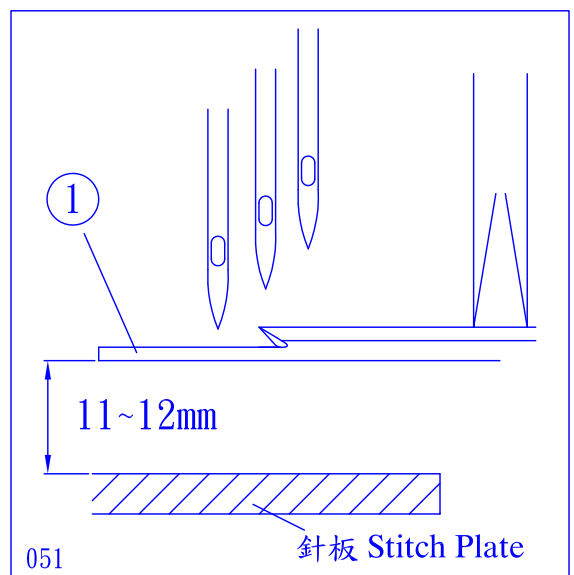
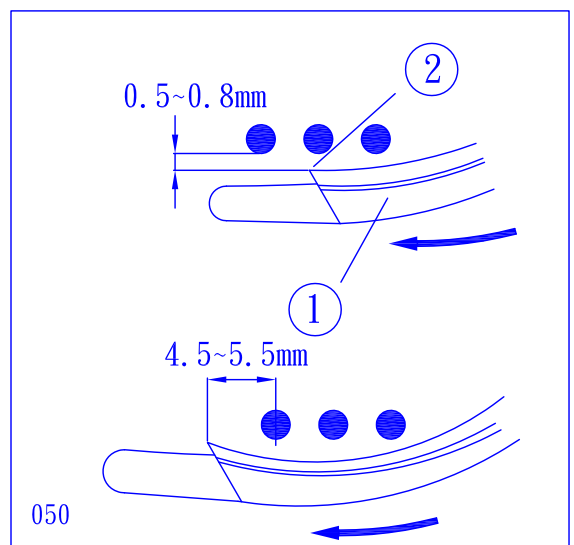
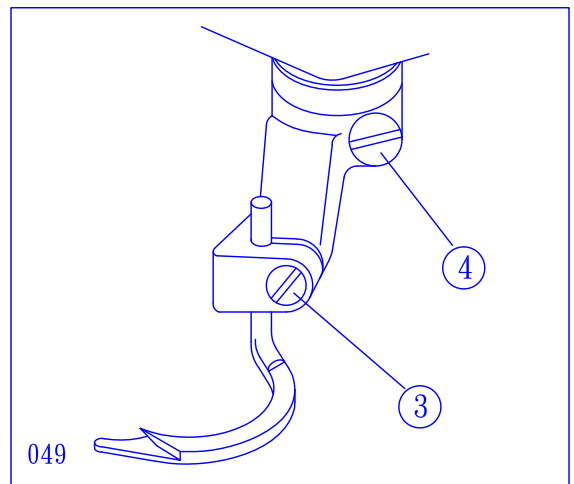

6.4.2 上飾線導板的調整

Top Cover Thread Guide Adjustment

- (1) 鬆開上飾線導板①的螺絲②(圖052)
Loosen the screw ② of the top cover thread guide ①. (See Fig. 052.)
- (2) 調整上飾線導板①的下緣與上勾針的表面0.5 mm的間隙(圖052)
Adjust the top cover thread guide ① so that the clearance between the top surface of the spreader ③ and the bottom surface of the top cover thread guide ① is 0.5 mm. (See Fig. 052.)
- (3) 當下勾針③前進到右死點時，調整尖點④在上飾線導板①狹長孔的中心點。然後鎖緊螺絲②(圖052 和圖053)
Adjust the spreader ③ so that the hook ④ is at the center of the slot on the top cover thread guide ① when the spreader ③ is to the farthest right. Then, tighten the screws ②. (See Figs. 052 and 053.)

6.4.3 上飾線過線桿的調整 Top Cover Thread Eyelet Adjustment

- (1) 鬆開上飾線過線桿⑤的螺絲⑥(圖053)
(1) Loosen the screw ⑥ of the top cover thread eyelet ⑤. (See Fig. 053.)
- (2) 當針棒移動到最低位置，調整上飾線導板①的上緣與上飾線過線桿下緣⑤的間隙為1.0 mm(圖052)
Adjust the top cover thread eyelet ⑤ so that the clearance between the top surface of the top cover thread guide ① and the top cover thread eyelet ⑤ is 1.0 mm when the needle bar is at the lowest point. (See Fig. 052.)
- (3) 上飾線導板①的狹長延伸孔與上飾線過線桿⑤的孔必須對齊(圖053)
Align the hole of the top cover thread eyelet ⑤ as an extension of the slot on the top cover thread guide ①. (See Fig. 053.)
- (4) 鎖緊螺絲⑥(圖053)
Tighten the screw ⑥. (See Fig. 053.)

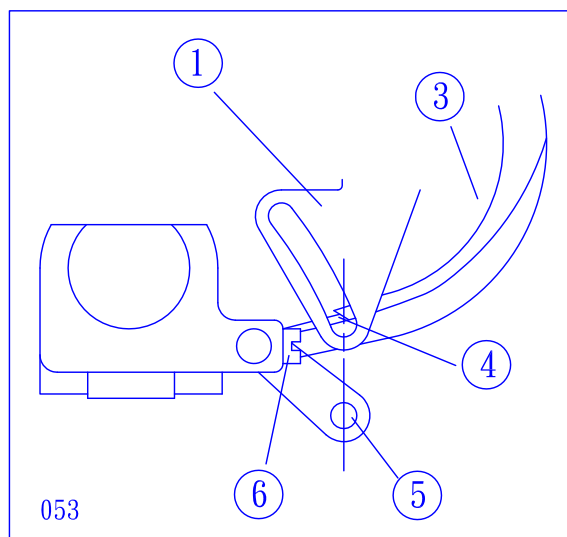
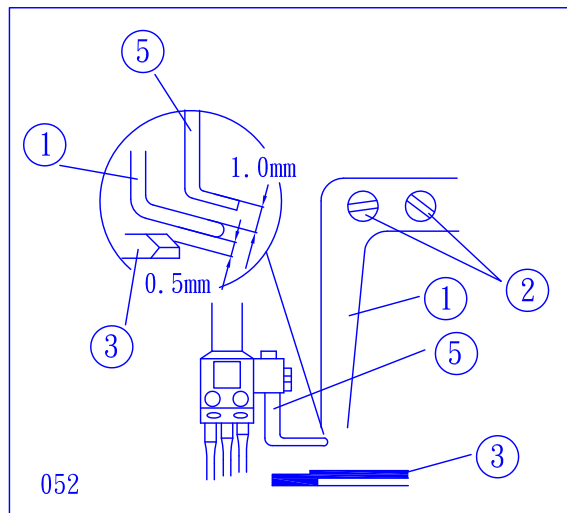

6.5 針與下勾針的調整 Needle and Loper Adjustment

6.5.1 調整下勾針的距離 Loper's Distance Adjustment

當針棒在最低點而下勾針在右死點(起點)時，下勾針針尖到右針中心的距離L，依針距不同而定。請參照(表二)調整正確位置。

The looper's distance (L) from the tip of the looper ① to the center of the right needle when the needle is at the lowest point and the looper ① is to the farthest right varies depending on needle distance. Adjust looper's distance as shown in Table 2.

鬆開下勾針座 ② 的螺絲 ③ 和定位環 ④ 的螺絲 ⑤。然後調整下勾針 ① 到正確的位置。

Loosen the screw ③ on the looper holder ② and the screw ⑤ on the looper holder collar ④. Then, position the looper ①.

一旦位置調好後，鎖緊螺絲 ③ 和 ⑤。

Once the looper has been positioned, tighten the screws ③ ⑤.

6.5.2 下勾針角度和高度的調整(圖 054)

Looper Angle and Height Adjustment

把下勾針 ① 插入下勾針座 ② 到底然後鎖緊螺絲 ⑥ 此時下勾針有 2° 的斜度。

Insert the looper ① to the end of the looper holder ② and tighten the screw ⑥. Loper height and looper installation angle (2°) are fixed.

6.5.3 下勾針前後位置的調整(圖 057)

Looper Front-and-Rear Position

(1) 旋轉機器手輪直到下勾針的尖點移轉到左針的中心點。

Turn the machine pulley until the tip of the looper ① comes to the Center of the left needle ⑦.

(2) 鬆開螺絲 ③ 和 ⑤ 後，調整下勾針座 ② 和定位環 ④ 使左針 ⑦ 的後側與下勾針 ① 尖點的間隙為 0.2~0.3mm。

Loosen the screws ③ ⑤ to adjust the looper holder ② together with the looper holder collar ④ so that the clearance between the backside of the left needle ⑦ and the tip of the looper ① is 0.2-0.3 mm.

(3) 鎖緊螺絲 ③ 和 ⑤。

Tighten the screws ③ ⑤.

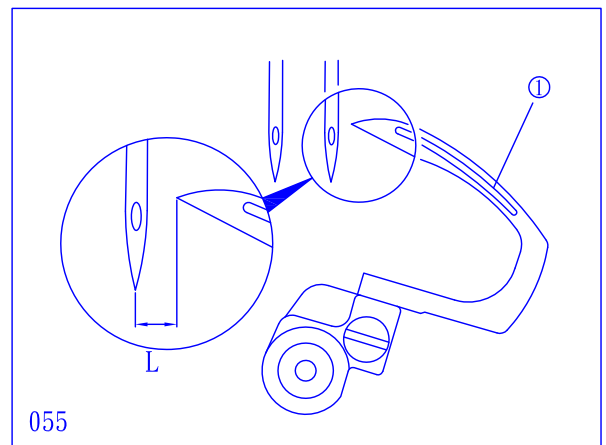
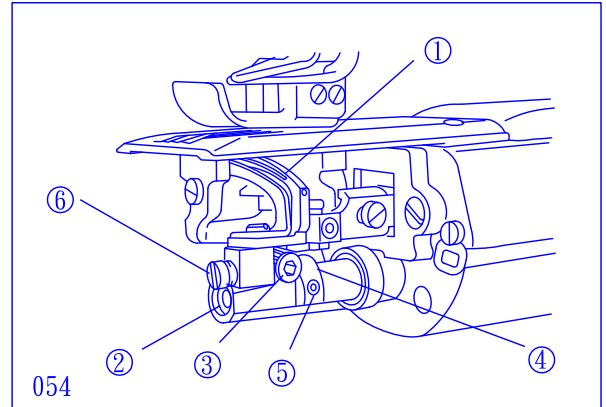

表二 Table 2

針距(型號碼) Needle distance(Code)	下勾針到右針中心的距離 Looper's distance(L)
(2針)(2Needle)4.0mm(240)	4.4-4.6mm
(2針)(2Needle)4.8mm(248)	4.0-4.2mm
(3針)(3Needle)5.6mm(356)	3.5-3.6mm
(3針)(3Needle)3.6mm(360)	3.3-3.4mm
(4針)(4Needle)6.0mm(460)	3.3-3.4mm
(4針)(4Needle)6.4mm(464)	3.2-3.4mm

補充 SUPPLEMENT

把下勾針 ① 拆卸下來，這樣針座 ② 比較容易重新安裝
Removing a set of the looper ① and the looper holder ② will be easily reset.

把定位環 ④ 的固定梢插入針座 ② 的孔到底，使他們密合後再鎖緊針座上的螺絲 ③ 然後調整針及下勾針的間隙。

Fit the pin of the looper holder collar ④ into the hole of the looper holder ②, press the parts together and tighten the screw ③ on the looper holder ④. Then, check the clearance between the needle and the looper ①.



注意 CAUTION

- 如果定位環和針座沒有密合，針可能會與下勾針碰撞造成損壞。
Press the looper holder ② and looper holder collar ④ together. If the needle and looper ① contact one another, they may break.
- 當鎖緊螺絲 ③ 後，請再次檢查下勾針前後的位置是否正確
When tightening the screw ③, the looper ① may move in the front-and-rear position. After tightening the screw ③, recheck the front-and-rear position of the looper ①.

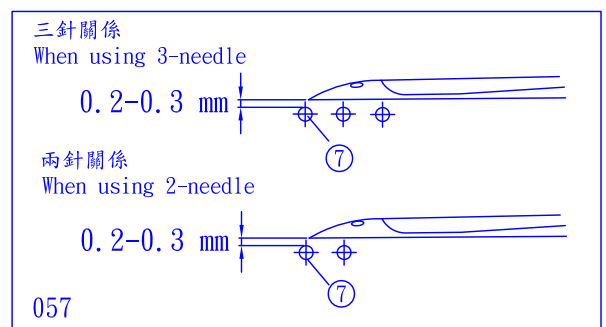

6.5.4 調整針的高度(圖 058)

Needle Height Adjustment

- (1) 把最左針裝到針榴上
Set the needle in the left needle installation hole of the needle clamp.
- (2) 卸下螺絲①
Remove the screw①.
- (3) 鬆開針棒驅動架的螺絲②並調整針棒與針板在垂直的方向。不同針距組從左針尖點到針板，表面的尺寸如附(表三)
Loosen the screw② of the needle bar bracket and adjust the needle bar in the vertical direction so that the tip of the left needle is the height (N) given in Table 3 from the stitch plate, then tighten the screw② of the needle bar bracket.
- (4) 檢查針的落點要落在各針板孔的中心點後(圖060)，鎖緊螺絲②
Check the needle drops in the center of the needle hole on the stitch plate, then tighten the screw (060) of the needle bar bracket.②
- (5) 重新鎖上螺絲①(圖 059)
Retighten the screw①.

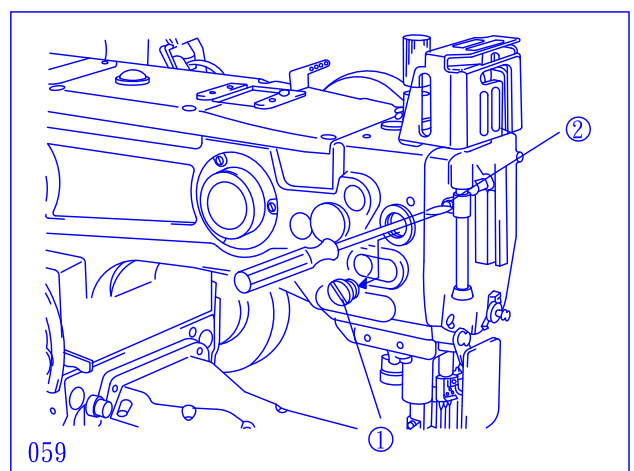
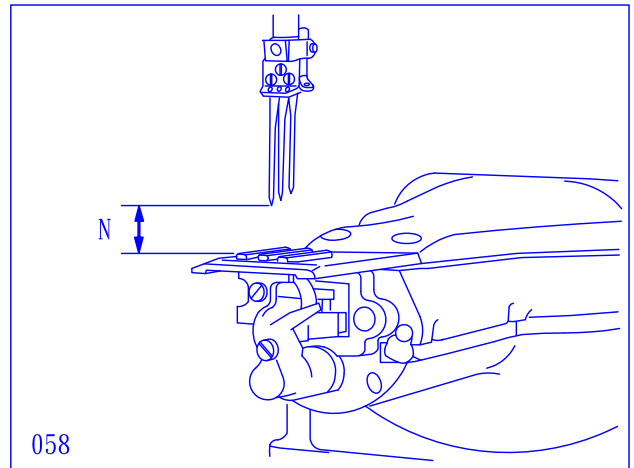

表三 Table 3

針距 Needle distance	型號碼 Code	最左針高度 Left Needle height(N)
(2針)(2Needle) 4.0mm	240	10.8-11.0mm
(2針)(2Needle) 4.8mm	248	10.5-10.7mm
(3針)(3Needle) 5.6mm	356	10.2-10.4mm
(3針)(3Needle) 6.0mm	360	10-10.2mm
(4針)(4Needle) 6.0mm	460	10-10.2mm
(4針)(4Needle) 6.4mm	464	9.9-10.1mm

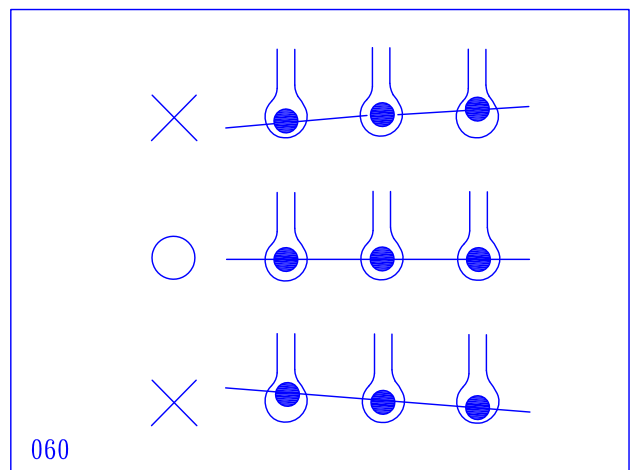

6.6 後頂針片的調整 Needle Guard(Rear) Adjustment

6.6.1 後頂針片高度的調整 Needle Guard(Rear) Height Adjustment

(1) 鬆開螺絲②

Loosen the screw②.

(2) 當下勾針前進到右針的中心點時，調整左針針孔下緣與後頂針片的背脊線a對齊。

Set the ridge line "a" of the needle guard(rear)① to the same height as the bottom of the left needle eye when the looper is at the center of the right needle.

(3) 鎖緊螺絲③

Tighten the screw③.

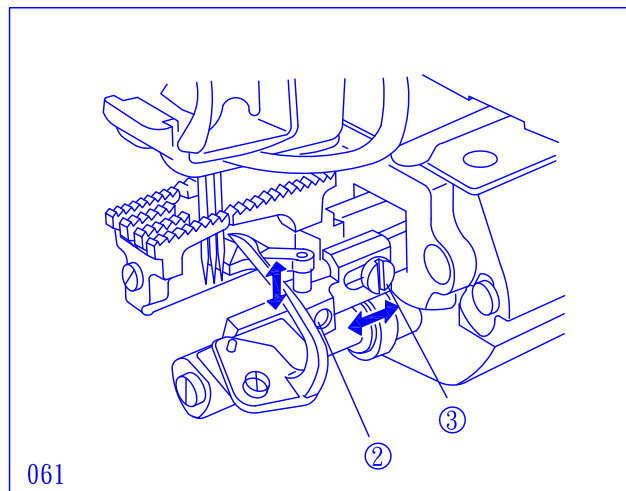

6.6.2 調整後頂針片前後的位置

Needle Guard(Rear) Front-and-Rear Position Adjustment

(1) 鬆開螺絲②③。

Loosen the screws②③.

(2) 當下勾針的尖點在右針的中心點時，用頂針片去推右針使右針與下勾針有0-0.05mm的間隙，在此同時，調整後頂針片與左針有0-0.05mm間隙。

When the looper tip is at the center of the right needle, the looper pushes the right needle, therefore push the right needle with the needle guard(rear)① so that the clearance between the needle and the looper is 0-0.05 mm. Also at this time, adjust the angle and front-and-rear position of the needle guard(rear) so that the clearance between the left needle and the needle guard(rear)① is 0-0.05 mm.

(3) 檢查中間針和左針針孔下緣與後頂針片相接觸。

Check that the middle and left needles start contacting the needle guard(rear) at a point below the needle eye.

(4) 鎖緊螺絲②③。

Tighten the screws②③.

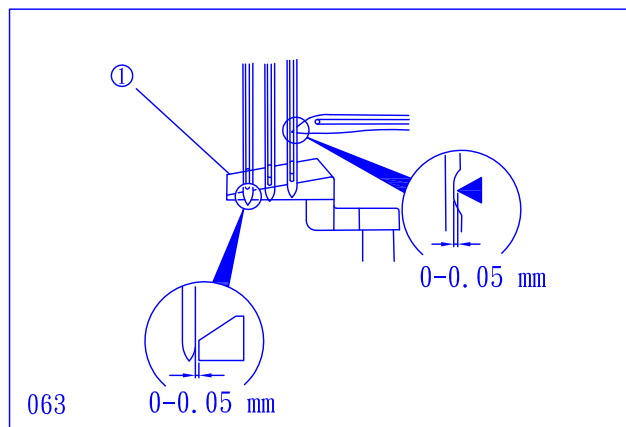
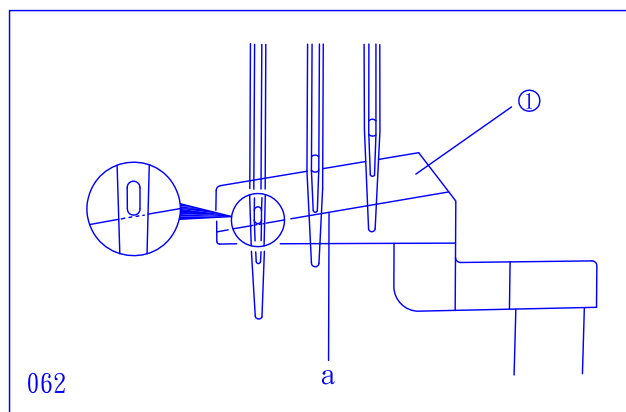

6.7 調整前頂針片 Needle Guard(Front) Adjustment

(1) 鬆開螺絲⑤，當下勾針尖點在左針的中心點時，調整前頂針片與各針的間隙約為0-0.3mm④

Loosen the screw⑤ and position the needle guard(front)④ so that the clearance between it and each needle is 0-0.3 mm when the looper tip is at the center of the left needle.

(2) 鎖緊螺絲⑤

Tighten the screw⑤.

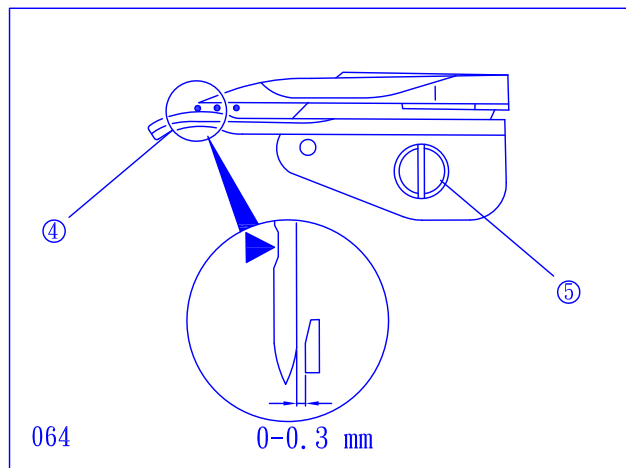

6.8 調整送布齒的高度 Feed Dog Height Adjustment

6.8.1 標準位置 Standard Position

當送布齒在最高點時，齒尖與針板表面距離為1.0~1.2mm。各送布齒要與針板表面要等高且平行。

When the feed dog is at the highest point, the tail end of the main feed dog ② is 1.0-1.2 mm from the top surface of the stitch plate. When the feed dog rises to the same height as the top surface of the stitch plate ⑦, the differential feed dog ① and the main feed dog ② are parallel to the stitch plate ⑦. Set the differential feed dog ①, middle feed dog ③ and main feed dog ② to the same height.

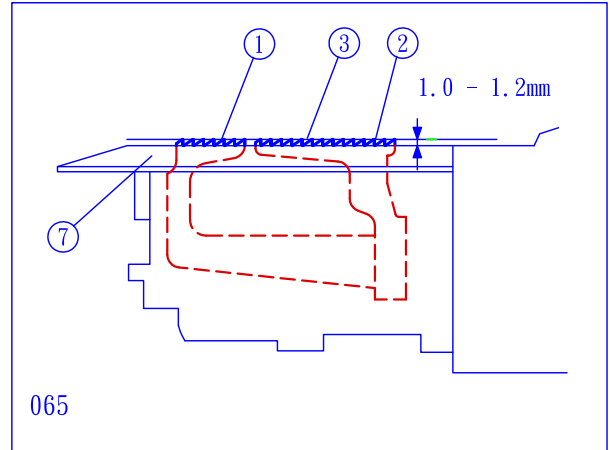

6.8.2 調整 Adjustment

鬆開差動齒 ① 的螺絲 ④，主齒 ② 的螺絲 ⑤ 和中間齒 ③ 的螺絲 ⑥，調整好位置後，鎖緊螺絲 ④ ⑤ ⑥。

Loosen the screw ④ of the differential feed dog ①, the screw ⑤ of the main feed dog ② and the screw ⑥ of the middle feed dog ③, and position the feed dogs. Once the feed dogs have been positioned, tighten the screws ④ ⑤ ⑥.

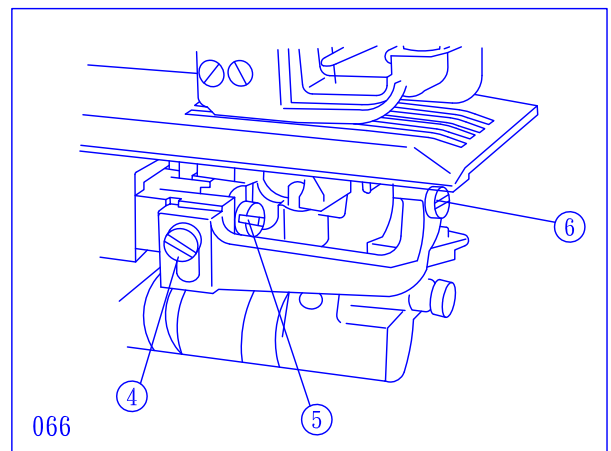

6.9 調整押腳的位置 Presser Foot Position Adjustment

鬆開螺絲 ⑫ 左右調整押腳使針板上針孔在各押腳溝的中心。

Correctly set the presser foot ⑧ on the presser bar ⑨ and position the presser foot so that the needles ⑩ drop in the center of the needle hole ⑪. Loosen the screw ⑫ on the presser foot ⑧ and turn the presser foot ⑧ to the left and right until the needles ⑩ drop in the center of the needle hole ⑪ on the presser foot ⑧.

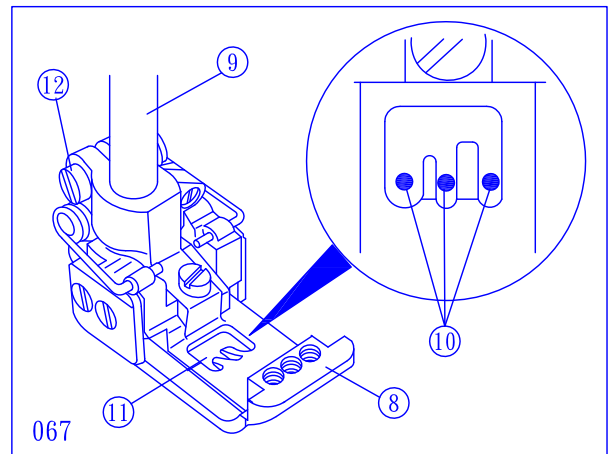

6.10 拆卸及重新安裝押腳 Removing and Resetting Presser Foot

6.10.1 如何拆卸(圖 068)

How to Remove

- (1) 鬆開螺絲 ①。
Loosen the screw ①.
- (2) 往下押提升桿 ③ 使押腳能拆卸下來。
Press the lifter lever ③ downward and remove the presser foot ②.

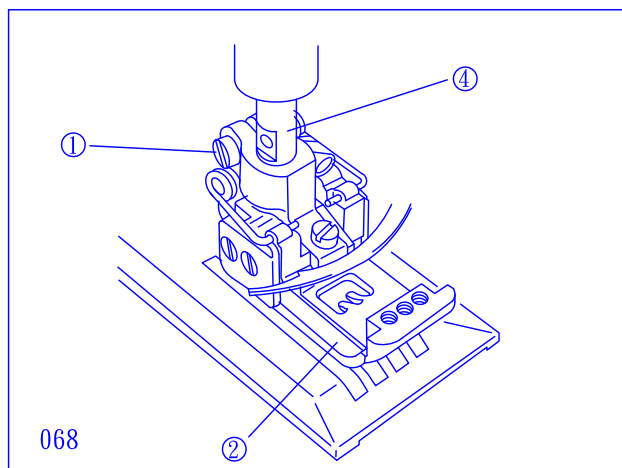

6.10.2 如何安裝(圖 069)

How to Reset

- (1) 往下押提升桿 ③ 直到押腳棒 ④ 插入押腳孔 ②。
Press the lifter lever ③ downward until inserting the presser foot ② into the presser bar ④.
- (2) 左右調整押使針板上的針孔在各押腳溝的中心，然後鎖緊螺絲 ①。
Position the presser foot ② as explained in "6.9 Presser Foot Position Adjustment"(068), and tighten the screw ①.

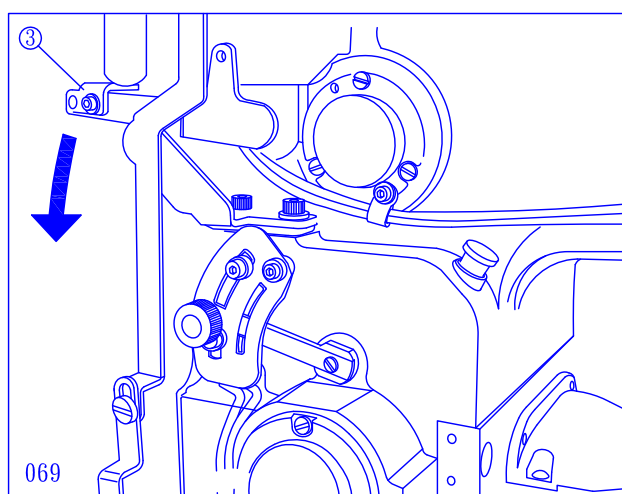

6.11 潤滑油的更換 Changing the Oil

6.11.1 Oil Changing Interval

新機器運轉約200小時(大約一個月)後,請更換潤滑油,然後每年更換一次或兩次即可。

With a new sewing machine, change the lubricating oil after about 200 hours(approx. 1 month) of use. After that, change the oil once or twice a year.

6.11.2 如何更換(圖 070)

How to Change

- (1) 拆開皮帶蓋。(5頁)
Remove the belt cover.(See page 5.)
- (2) 從機器上把皮帶卸下來。(4頁)
Remove the V-belt from the sewing machine.(See page 4.)
- (3) 把機器從車板上卸下來。
Remove the sewing machine from the machine table.
- (4) 準備器皿來裝卸下來的油。
Set a container for catching the oil underneath the drain hole.
- (5) 鬆開螺絲①把油卸出。
Remove the drain hole screw①.
The oil is drained.



注意 CAUTION

請勿讓油滴在皮帶或機器手輪上
Be careful not to get oil on the V-belt or machine pulley.

- (6) 重新鎖緊螺絲①
Reset the drain hole screw ①.
- (7) 打開油鏡②
Remove the seal plug ②
- (8) 更換新油, 注入油孔。
Change new oil.
- (9) 把機器重新裝上桌板
Set the sewing machine on the machine table.
- (10) 裝上皮帶及皮帶蓋(請參照 第4和5頁)
Hang the V-belt around the motor pulley and reset the belt cover.
(See pages 4 and 5.)

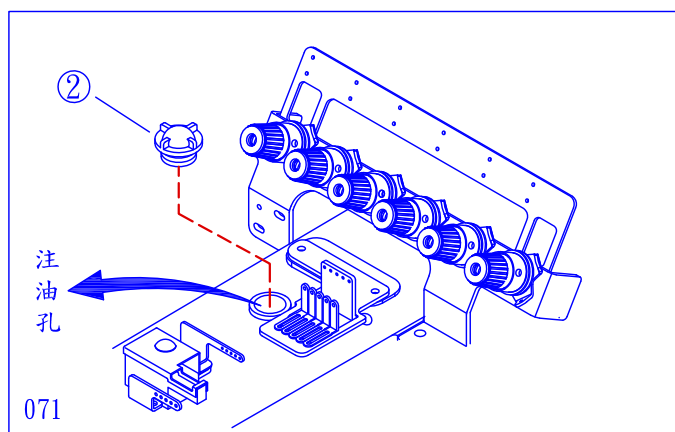
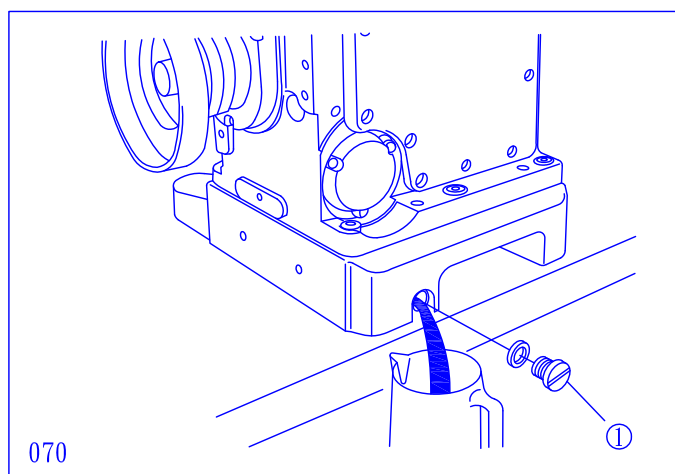

6.12 檢查濾油器及更換(圖 072)

Oil Filter Check and Replacement

- ◇ 如果潤油器阻塞太多的灰塵，請每6個月更換新的濾油器。
Oil is not properly supplied if the oil filter ① becomes clogged with dirt. Check the filter for clogging and breakage every 6 months.
- ◇ 如果油嘴噴出油量太少或太多油泡但油表油量正常，請也檢查濾油器是否該更換。
If very little oil is sprayed from the nozzle despite a sufficient charge of oil or if there are many bubbles in the oil, check and replace the oil filter.

6.12.1 如何更換濾油器 How to Check and Replace

- ◇ 把油蓋②拆卸下來，拉出O型環③和濾油器①做檢查
Remove the oil filter cap ②, pull out the O-ring ③ and the oil filter ①, and check the oil filter.
- ◇ 如果濾油器①卡太多棉屑或灰塵，請清理或更換新的。
If the oil filter ① is clogged with dirt, clean or replace with a new filter.
- ◇ 如果濾油器①破損，請更換新的。
If the oil filter ① is broken, replace with a new filter.

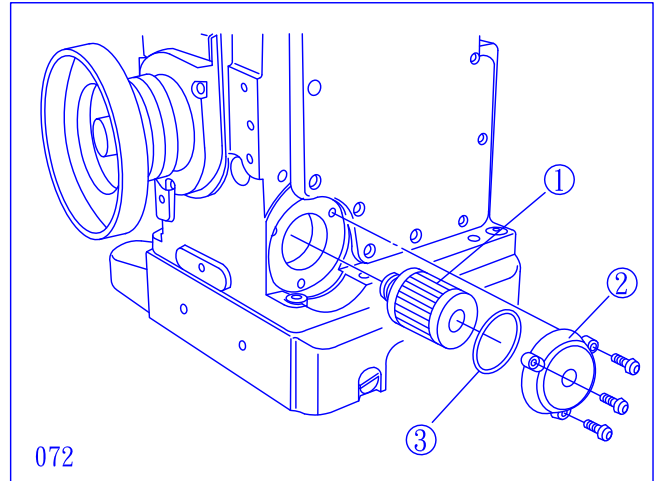

注意 CAUTION

- 當拆卸濾油器時，小心油流出。
When removing the oil filter cap ②, oil in the oil filter ① may spill out.
- 把濾油器推入到底作正確安裝。
Insert the oil filter ① completely to rear to install properly.

7. 故障排除 Troubleshooting

故障原因 Trouble	檢查項目 Check item	解決方法 Remedial action	Ref. page
跳線 Skip Stitch	線是否穿錯 Is the thread wrongly threaded?	請正確穿線 String the thread properly.	
	針彎曲或針尖斷了 Is the needle bent or the tip broken?	換針 Replace the needle.	
	線太緊 Is the thread too tightened?	從鬆線器把線調鬆一點 Loosen the thread at the tension unit.	
	針與下勾針、頂針片間隙，同步是否正確 Are the timing and clearances of the needles, looper and needle guards correct?	參照操作手冊調整正確的間隙及同步 Correct the timing and clearances of the needles, looper and needle guards.	
	是否針太細而線太粗 Is the needle too thin for the thread?	換正確規格的針或線 Either replace the needle or the thread with the proper size.	
	是否針沒有裝到針榴的底部或針的方向不對 insertion depth)? Is the needle wrongly attached (direction or	請正確地將針裝好 Attach the needle correctly.	
斷線 Thread breakage	是否線卡在過線孔 Is the thread caught on the eyelet?	移除卡線 Remove the caught thread.	
	是否穿線錯誤 Is the thread wrongly threaded?	請正確穿線 String the thread properly.	
	是否線太緊 Is the thread too tightened?	從鬆線裝置調鬆一點 Loosen the thread at the tension unit.	
	是否針太粗而線太細 Is the needle too thick for the thread?	請更換正確規格的針或線 Either replace the needle or the thread with the proper size.	
	線的品質不好 Is the thread good quality?	請使用好品質的線 Use a good quality thread.	
	是否針過熱而燒線 Did the thread break under heat?	請使用砂油盒 Use the SP device.	
	是否過線孔損壞或下勾針線太緊或其它原因 Is thread damaged by eyelet, looper tension, etc?	更換或修理相關的零件 Either repair the damage or replace with a new part.	
斷針 Needle breakage	針是否正確接觸下勾針 Did the needle contact the looper?	調整針、下勾針及頂針片正確的間隙 Correct the clearances of the needles, looper and needle guards.	
線太緊造成車縫不平整 Improper thread tension	是否穿線錯誤 Is the thread wrongly threaded?	請正確穿線 String the thread properly.	
	檢查針線和下勾針線的線量是否正常 Are the needle threads and looper thread properly balanced?	調整鬆線器使線量正常 Correct the balance at the tension unit.	
線張力不均勻 Uneven tension	是否穿線錯誤 Is the thread wrongly threaded?	請正確穿線 String the thread properly.	
	檢查針線和下勾針線量是否正常 Are the needle threads and looper thread properly balanced?	調整各線的張力均勻 Correct the balance at the tension uit.	
油嘴無法噴油 Oil does not come from nozzle.	油量低於油鏡上的油線 Is oil level below the line on the oil gauge?	加油 Add oil.	
	濾油器卡布屑及灰塵 Is the oil filter clogged?	換新的濾油器 Replace the oil filter.	

8. 規格 Specifications

品名 Description	三針筒型雙面飾綳縫機 3-Needle Cylinder Bed Interlock Stitch Machine
材積 Dimensions	430(L)mm x 284 (W)mm x 360(H)mm
筒座圓周 Cylinder circumference	160 mm
重量 Weight	65 kg
縫目形式 Stitch type	ISO 406,407,602,605
功用 Application	多樣薄到中厚料針織布車縫 Plain stitch, overlapped seam, hemming, and welt seam for knitted fabrics
最高速度 Sewing speed	Max. 4500 rpm (during intermittent operation)
縫目長度 Stitch length	Number of stitches(1.2-4mm) 6-21 stitches/25.4 mm 7.5-25 stitches/30 mm
針 Needle system	TVx7GAS***#9-#14 (Standard #10)(65-90)
針距 Needle distance	3-needle: 4.8,5.6,6.4 mm (2-needle: 3.2, 4.0 mm)
針行程 Needle stroke	31.5 mm
抬押腳高度 Presser foot lift	最大(配備上勾針時)8 mm (With spreader)
送料調整 Feed regulation	按鈕機構 Pushbutton system
差動比 Differential ratio	Max. Normal differential 1:2, Max. reverse differential 1:0.8
差動比調整 Differential feed regulation	外裝式 External lever
給油系統 Lubrication	油泵自動給油 Automatic lubrication by trochoid-shaped pump
潤滑油 Lubricating oil	CPC SPINDLE OIL R22 or equivalent
油槽容量 Capacity of oil reservoir	600 cc
安裝 Installation	安裝在桌板上 Table top type

9. 針定位說明 Needle up and Down Position

9. 針定位 Needle Position

請用3mm的內六角扳手，插入孔④內，放鬆三個螺絲，轉動手輪⑤
確認車針上停及下停的位置後，鎖緊孔④內三個螺絲

Loosen three screws inside the hole ④ Turn handwheel ⑤
to adjust up and down needle position and then fasten
the three screws inside the hole ④

9-1. 上停位置: 轉動手輪⑤針棒在最高點與下降0.5mm範圍內為標準
圖073，定位線⑥與手輪⑤第二圓孔對齊

Needle up-position: Turn handwheel ⑤ so that the
needle bar at the highest position to the position that
0.5 mm below its highest point. This position is equal to
the mark ⑥ align with the second hole of handwheel ⑤
(073)

9-1. 下停位置: 隨者上停位置確認後，針棒在最低點與上升3mm範圍內為標
準 圖074，孔④與手輪⑤第一圓孔約同一線

Needle down-position: Turn handwheel 5 so that the
needle bar at the lowest position to the position that
3 mm above its lowest point. This position is equal to
the hole ④ align with the first hole of handwheel ⑤
(074)

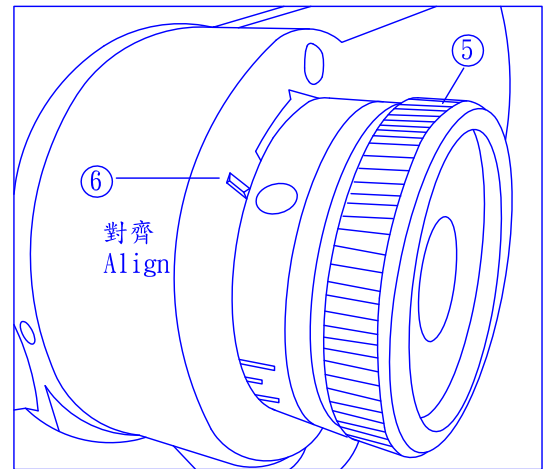

073

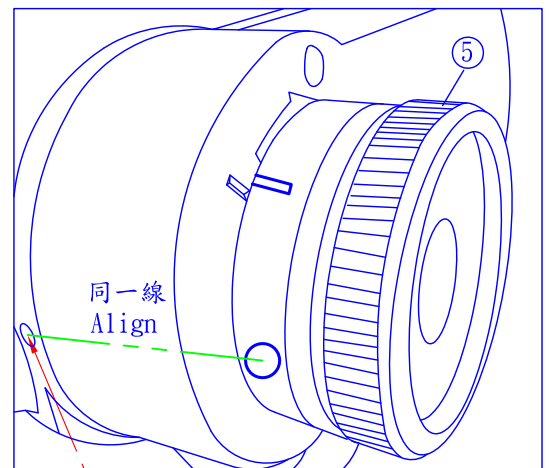

074

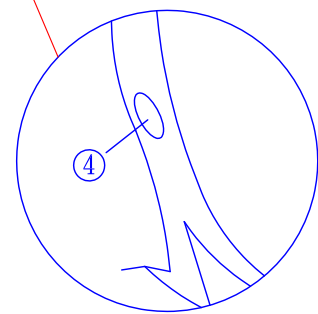

10. 穿線圖 Threading

底線穿法 Threading

◇請參照下圖正確穿線 (A針線)

Please see the picture below for threading.

<A Needle Thread >

◇把線頭拉到針的前面，線頭剪平後再穿過針孔 (B上飾線)

Pull out the thread until it comes to the front of the needle. Then, cut off the knot before pressing it through the needle eye. <B Top Cover Thread >

◇把線頭穿過上飾線過線桿 (C下勾針線)

Pull the thread until the knot comes out. <C Loper Thread >

◇把線頭穿過後，線頭剪平後穿入下勾針針孔

Pull the thread until the Knot comes out. Cut the tip with a pair of Scissors supplement

◇把提線托板①提升到頂點，以便穿下勾針線。

穿線以後壓①到底回到原來正確位置。

Looper Thread can be threaded easily, if the take-up holder is raised up.

After threading, return it to its original position.

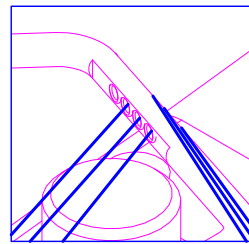

(A)

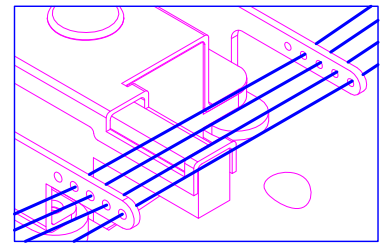

(C)

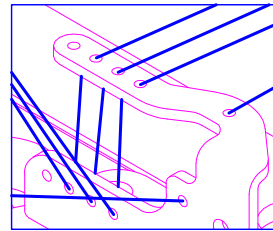

(B)

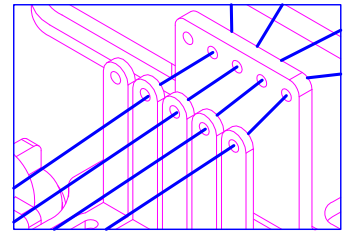

(D)

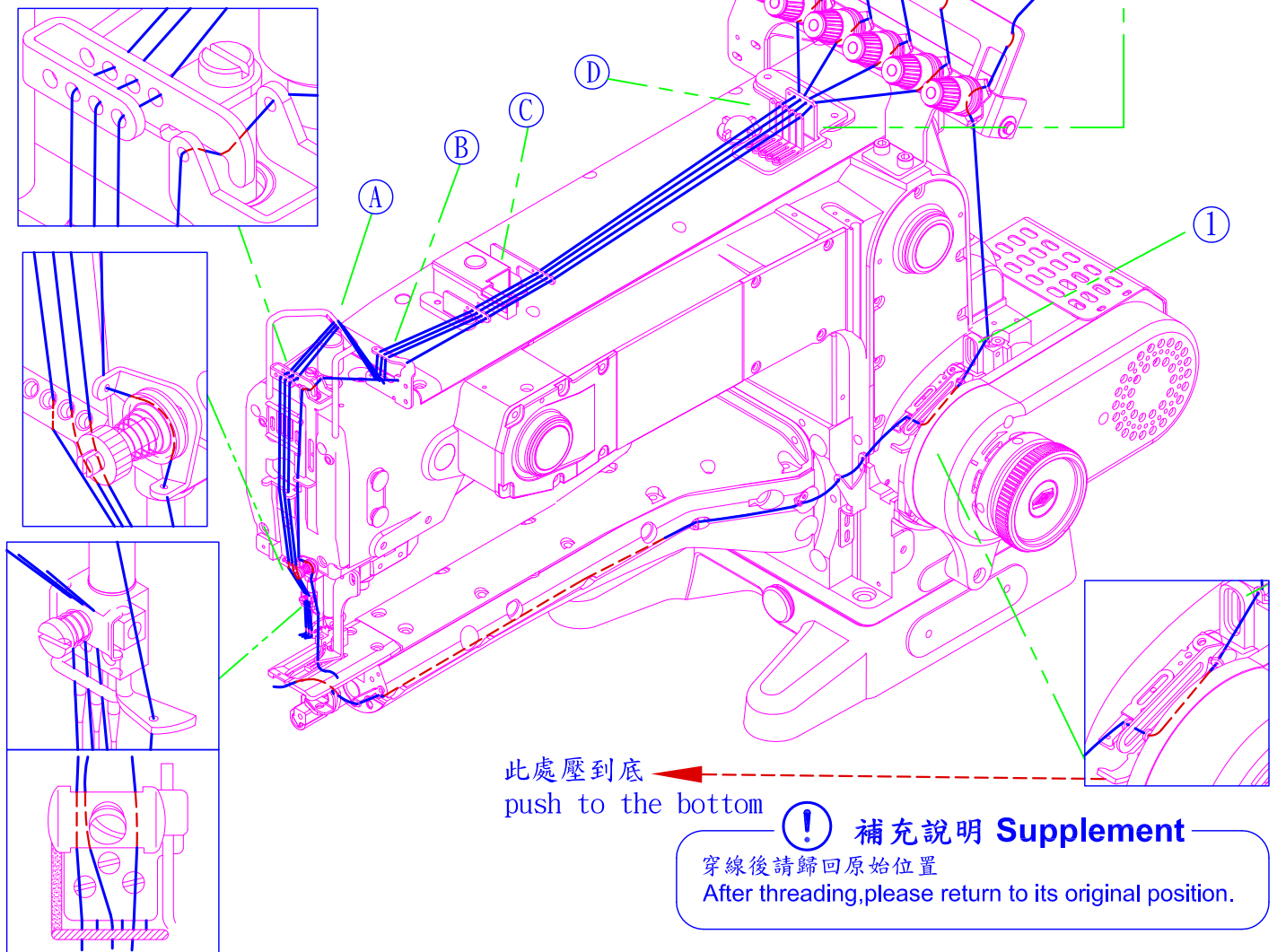

11. 縫目長度的調整 Proper operation

粗細針調整 Stitch length adjustment

3.2粗細針的調整

粗細針可以從1.2mm到4.0mm作任意調整,手輪上的每一刻度代表一縫目的長度(mm)

* 實際縫目的長度可能因布料的厚度和差動比不同而有所不同。(圖表四)

改變粗細針

(1)用左手壓下按鈕①直到鈕的底端接觸到內部零件。

(2)用右手依順時針方向轉動手輪③直到對刻劃②,內部零件進入凹槽再用力壓下按鈕①(077)

*轉動手輪③向順時針方向可調整縫目較長。②

*轉動手輪③向逆時針方向可調整縫目較短。②

仍然壓住按鈕①並用右手旋轉手輪③使上面記號與皮帶蓋上面的記號②對齊

(3)當調整好所要的粗細針放開按鈕①並檢查按鈕①已歸回原來位置並且手輪能順暢的轉動。(078)

Stitch length can be adjusted infinitely from 1.2 mm to 4.0 mm. Each graduation (Table 4) on the handwheel ③ indicates the length (mm) of one stitch.

Actual stitch length may vary depending on the type and thickness of fabric, and the differential ratio.

Check the pushbutton ① has returned to its original position completely, and the handwheel ③ returns smoothly.

To make the stitch length longer, turn the handwheel ③ clockwise. ②

To make the stitch length longer, turn the handwheel ③ counterclockwise. ②

With the pushbutton ① still depressed, align the scale marking of the handwheel ③ with the mark ② on the mark of the belt cover.

After the required stitch length is adjusted, check the handwheel ③ return completely to the released position and handwheel ③ rotate smoothly.

縫目長度 Stitch length (mm)	每英寸縫目針數 Number of stitches per inch	每30mm縫目針數 Number of stitches per 30 mm
4.0	6	7.5
2.5	10	12
2.0	12.7	15
1.2	21	25

表四 Table 4

◇表四 是每英寸和每30mm的縫目針數

Table 4 shows the number of stitches per inch and 30mm.

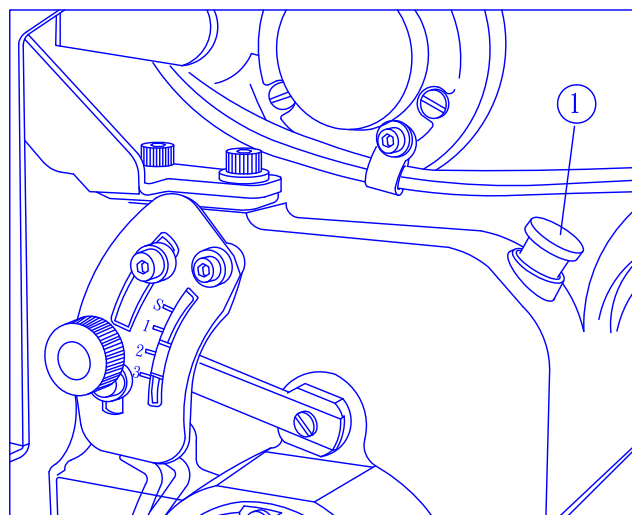

077

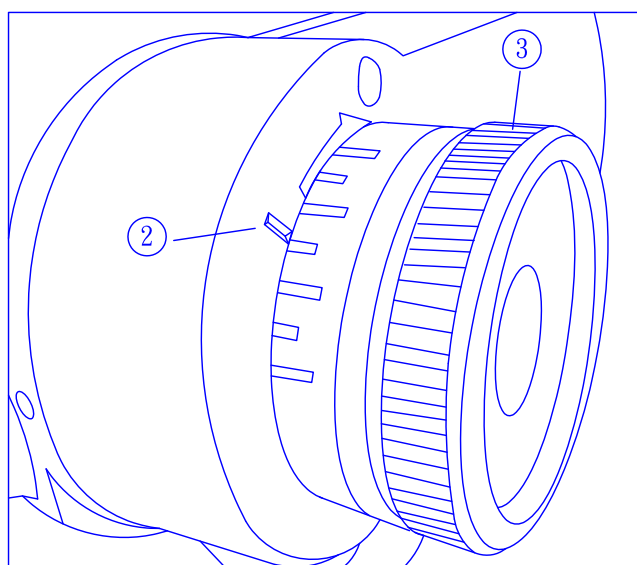

078

12. 踏板操作 Pedal Operation

操作方式 Operating procedure

3.3 操作的順序(圖079)

我們可以選擇位置①位置②來設定伺服馬達

以下將說明位置①位置②的操作

- (1)後踩踏板可將押腳升起。如③
 - (2)把布放到押腳底下然後前踩踏板，機器開始車縫。①
 - (3)放開踏板如②使針停在上停或下停的位置
 - (4)後踩踏板如③
- *針在上停位置時，針板下活動刀把針及下勾針的線切斷，且下勾針線頭被彈片夾住。
- *同時上切刀把上飾線切斷而押腳提起
- (5)放開踏板如②押腳放下。

3.3 Operation procedure 079

The setting for servo motor can be selected from ① position or ② position. The following is the procedure under ① position and ② position.

- (1) Heel back the pedal to raise the presser foot. ③
- (2) Place a fabric under the presser foot and toe down the pedal. ①
- (3) Release the pedal. ②The needle stops at the highest point. (In case of ① position.)
or the needle stops at the lowest point. (In case of ② position)
- (4) Heel back the pedal. ③
 - * The needle rises and stops at the highest point.
 - * The trimming knife mechanism operates to cut the needle and the looper threads under the stitch plate. The looper thread is held by the thread clamp.
 - * The top trimmer cuts and holds the top cover thread. the presser foot rises.
- (5) Release the pedal. ②The presser foot is lowered.

補助說明：

踏板在③②間押腳將抬高與放下，如果踏板在①時押腳無動作

Supplement

The presser foot can be raised and lowered by heeling back the pedal to the positions ② and ③, except for the pedal is toed down to the position ①

注意：

當布料放入並且押腳在最低點時，押腳底至針板間距至少保持5mm，假如上切刀下切接觸押腳，切刀將會損壞

Caution

Be sure to keep the height from the stitch plate to the bottom of presser foot under 5 mm, when the fabric is placed and the presser foot is lowered. If the Knife of top trimmer touches the presser foot, the knife can be damaged.

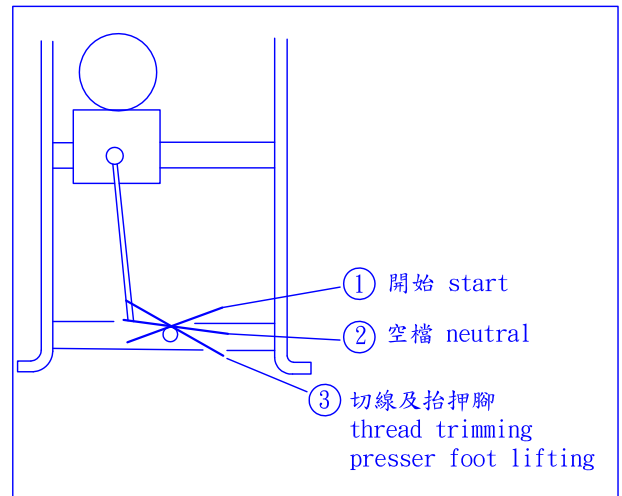

079

13.切線操作說明 Thread Trimming

13-1 針板拆卸與安裝 Removing and reinitalling stitch plate

- (1)轉動手輪使針在上停點的位置。
- (2)把押腳拆下
- (3)鬆開螺絲①把針板②拆下來
- (4)檢查驅動桿⑥是否已回歸原點
- (5)檢查針板②底下的活動刀⑤是否回歸原點。

1. Turn the hand pulley, and it makes the needle to the highest point.
2. Remove the presser foot.
3. Loosen the screw ①, and remove the stitch plate ②.
4. Check driving level to return original position.
5. Check movable Knife ⑤ under Stitch plate ② to return original position.

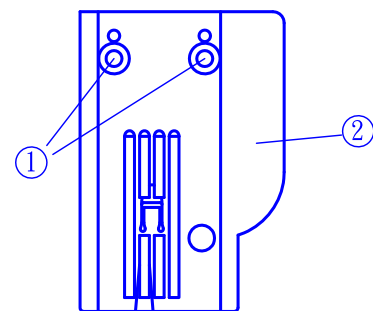
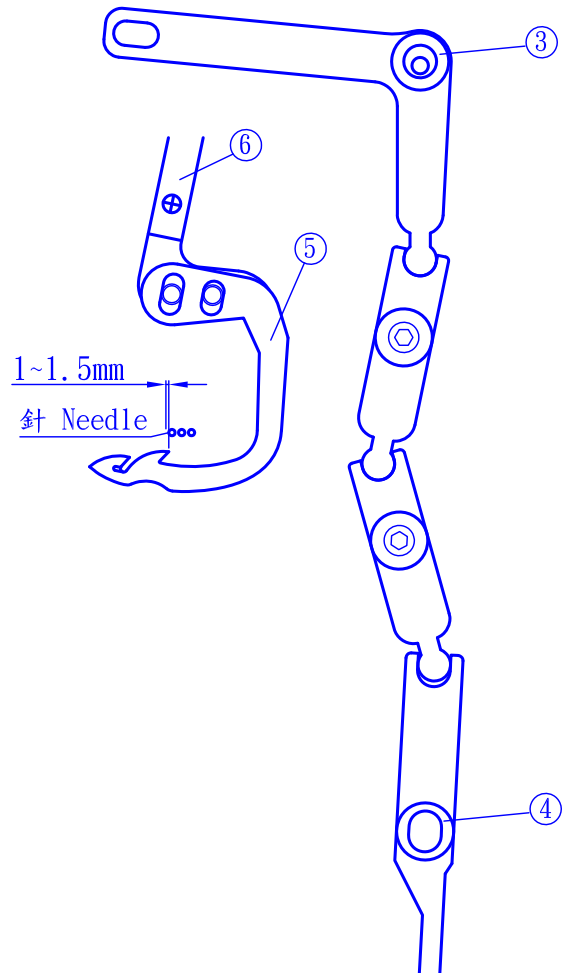

警告 WARNING

檢查驅動桿⑥與活動刀⑤有無確實鎖緊，以避免造成人員受傷及機器的損壞

To avoid injury to person and machine, please ensure driving level ⑥ and movable Knife are Securely fastened.



注意 CAUTION

ALWAYS turn the motor switch OFF and check that the motor has already stopped.

請關閉電源及確認馬達已完全停止運轉

13-2 下活動刀的機構 Trimming knife mechanism

13-2-1 活動刀的調整 Position of movable trimming knife

當活動刀前進到最頂點時，活動刀的第二尖點與最左針左緣有 1~1.5mm 的距離。

鬆開螺絲 ⑤ ⑥ 調整活動刀的行程，而 ③ ④ 是調整活動刀的角度位置。

When the air cylinder comes extreme out, the engagement between the tip of the hook and the edge of the longest needle is 1~1.5 mm. Make the adjustment by loosening the screw ③, ④ and ⑤, ⑥ The standard position of mark on screw ③ is set in 12-clock direction while the mark on screw ④ is set in 3-clock direction.

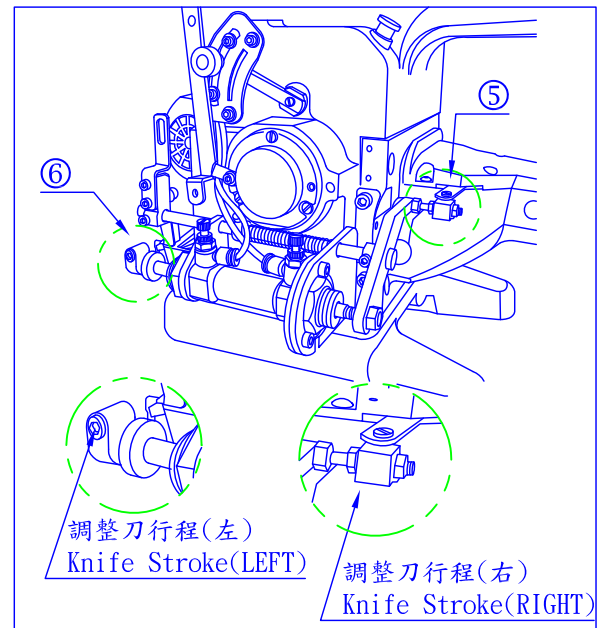

081



注意 CAUTION

調整活動刀後，請確認刀的行程及是否可回歸原點並且檢查安全開關

Readjust both coming out position and return position after adjusting the position of the movable trimming knife.

Also, be sure to check the detection switch.

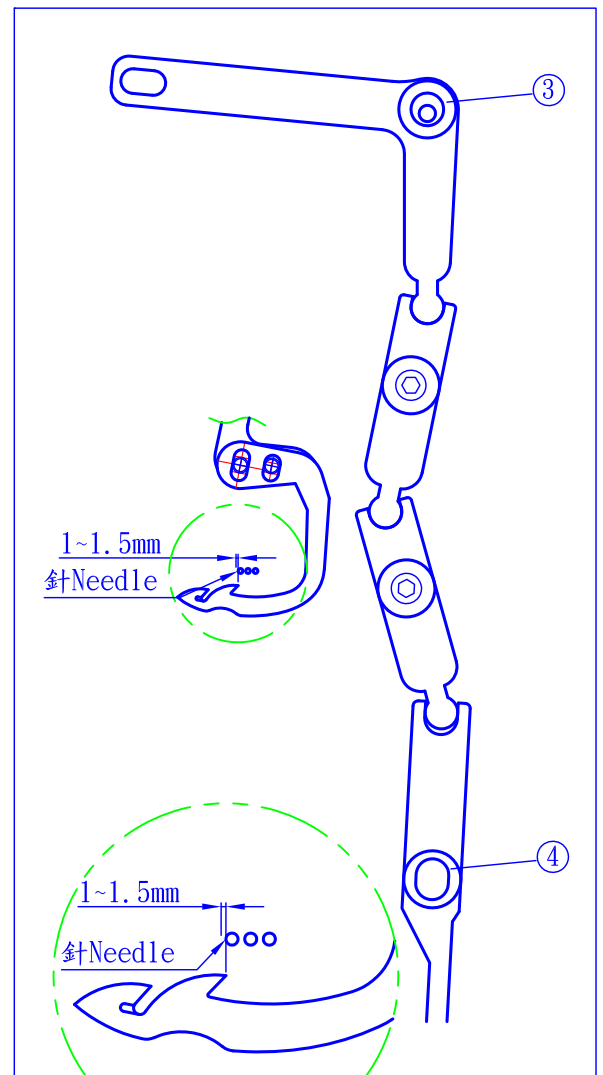

082

13-2-2 活動刀的回歸位置

Return position of movable trimming knife

當活動刀①回歸到後頂點時，活動刀的刀口與固定刀的刀口有0.3~0.5mm的距離如圖083。請微調螺絲3, 4, 5作以上調整。

When the movable trimming knife ① returns, make a engagement between the end of hook of moveable knife and blade of fixed knife for 0.3 ~ 0.5 mm. (083) make the micro-adjustment by Screw 3, 4 and 5. the angle of the knife.

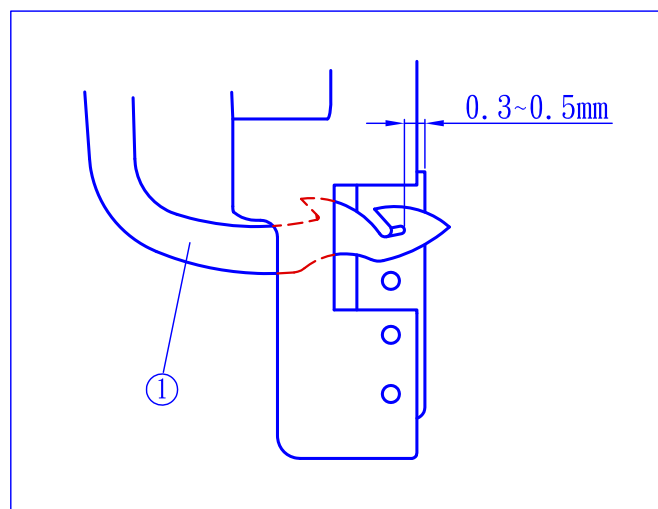

083



注意 CAUTION

檢查安全開關是否正常

Check the detection switch works good.

13-2-3 安全開關 Detector switch

- (1) 機器有安全開關③以確保活動刀完全回歸到原點, 活動刀如卡住及異常無法回歸原點, 控制箱將無法運作 (圖084)。
- (2) 控制箱面板上面旋轉符號②順時轉動表示功能正常。(圖085)

- (1) The detector switch ③ is equipped so that the machine does not work until the trimming knife returns to its original position. (084)
- (2) Check the icon ② on the leftmost of the display is rotating. If not, please check the detector switch and related parts. (085)

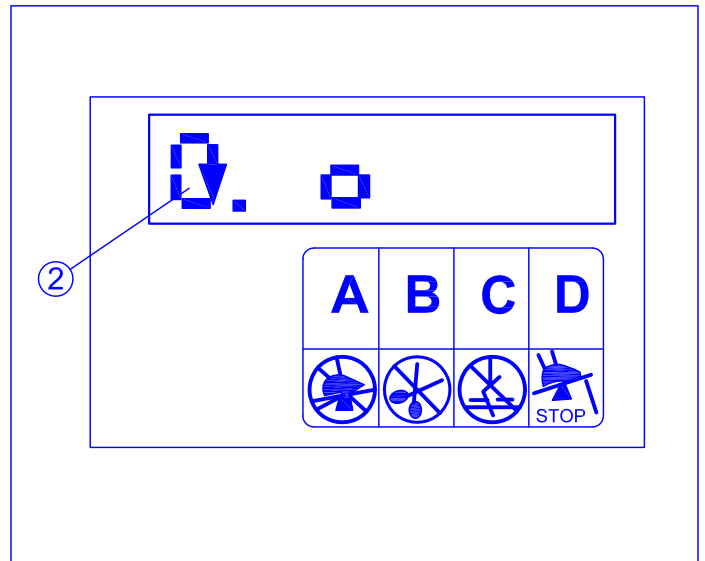

084



警告 WARNING

做以上調整時不可踩馬達踏板及確認馬達已關閉電源

Never touch the motor pedal.
Be sure to turn off the motor switch after adjustment or check.

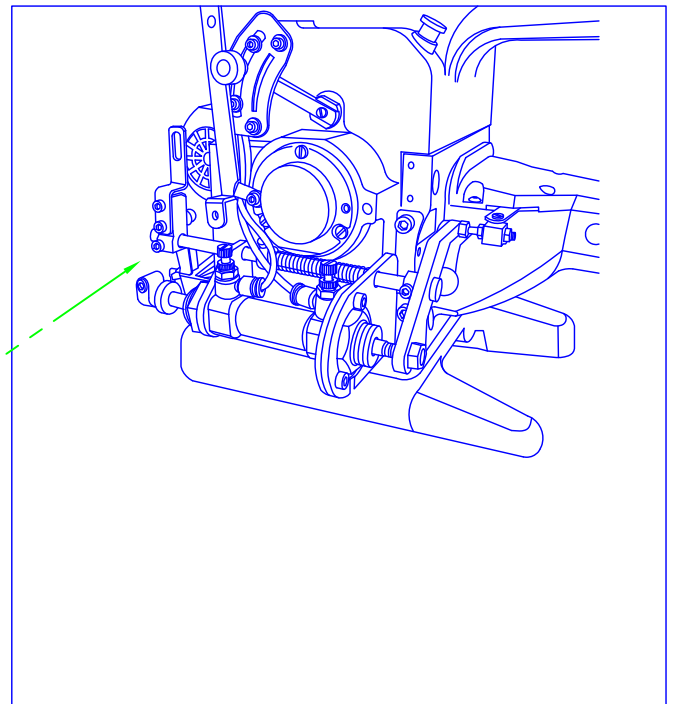
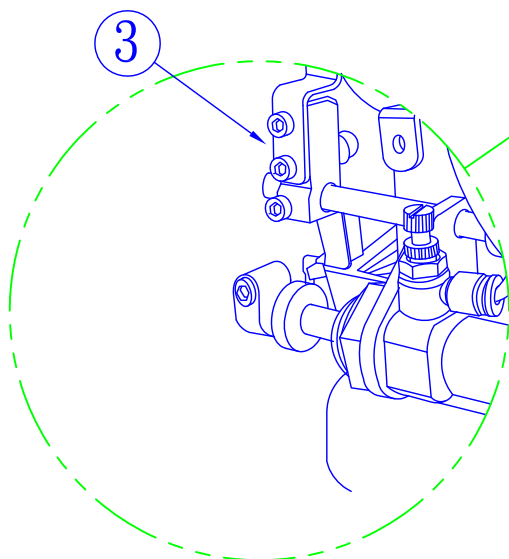

085

13-2-4 夾線片的調整 Thread clamp

- (1) L型夾線片①的右邊與活動刀第二刀口的內尖點對齊是正確的位置如(圖086)引所示
 (2) 旋轉螺絲②反時針方向, 夾線壓力變鬆, 而順時針方向則夾線壓力變緊。(圖088)

- (1) For the standard position of the thread clamp ①, make its right edge align with the end of hook on the movable trimmer knife as shown on the middle of 086.
 (2) To increase the pressure, adjust the screw ② clockwise.
 To decrease the pressure, adjust the screw ② counter-clockwise. 088

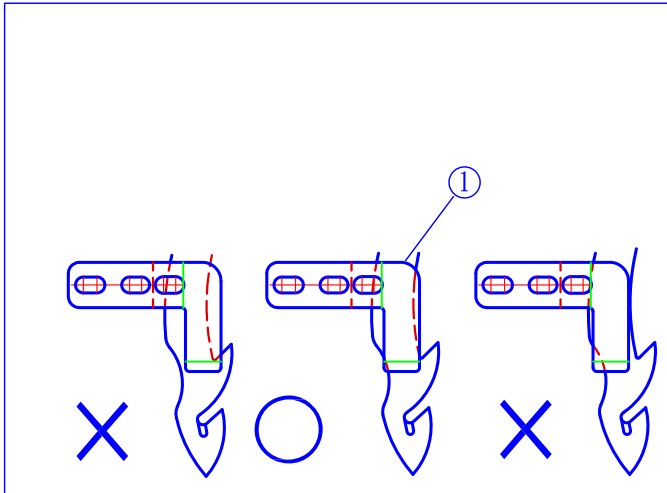

086

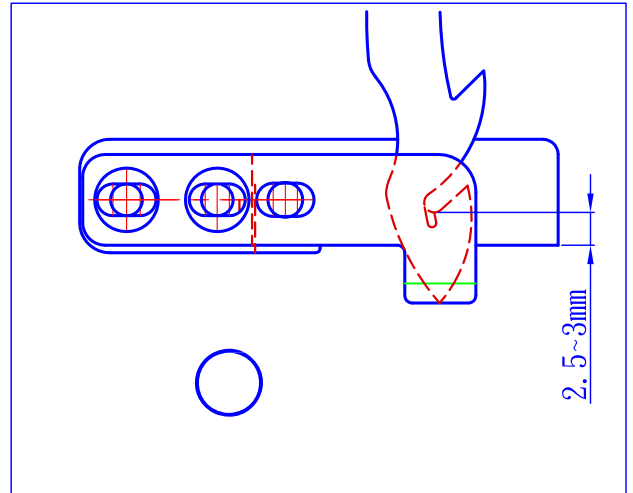

087

13-2-5 固定刀與活動刀關係 Movable trimming knife presser

活動刀恢復原點, 第一刀口與固定刀刀刃需重疊2.5mm~3mm
 When movable Knife returns to original Position, its blade should overlap with the blade of fixed Knife by 2.5~3mm. 087

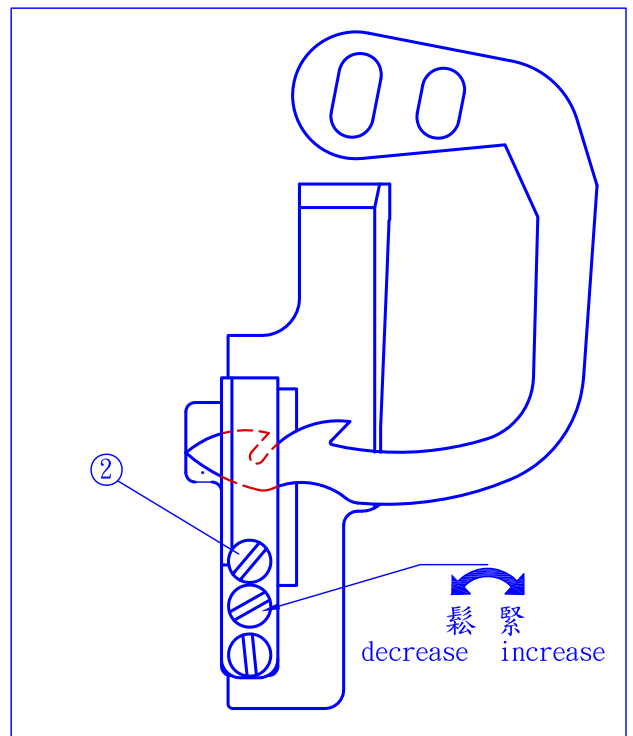

088

13-2-6 活動刀、針線及下勾針線的關係(圖089, 090)

Relation between movable trimming knife, needle thread, and looper thread

正確地調整切線裝置後請在車縫前檢查以下各組件

- *活動刀①必須穿過線圖③和④⑤並且刀尖②要能穿過下勾針線的前面勾住下勾針線。
- *當活動刀①回程時,針線及下勾針線要準確地被刀尖②和⑤勾入刀口內然後被固定刀剪斷。
- *如果以上步驟調整後仍然無法切線,請進一步作以下檢查
 - (1)是否針和針板孔沒有在正確的位置,是否針板溝與送料齒平行。
 - (2)是否針完全停在上停點。
 - (3)是否針與上下勾針的行程與沙拉組放線量同步。(請參照13-3,13-4 紗拉組放線機構)
 - (4)活動刀沒有正確調整。(請參照13-2 作調整)
 - (5)活動刀回程位置不對。(請參照13-2 作調整)

After all of the adjustment, thread correctly and check the following items before sewing.

- * The movable trimming knife ① should pass in the loops ③ and ④ and ⑤ the hook ② should pass the front of the looper thread.
- * When the movable trimming knife ① returns, the needle and the looper threads are hooked by the hooks ② and ⑤ respectively, and then they will be cut by the upper knife.
- * If the device does not work properly, even though the above-mentioned adjustment has been performed, check the following items and make adjustment.
 - (1) If the needle and needle fall of the stitch plate are in proper positions, and if the slot of stitch plate is parallel with the feed dogs.
 - (2) If the needle stops at the highest point.
 - (3) If the timing and the amount of the tension releaser is appropriate. (13-3,13-4)
 - (4) Coming out position of the movable trimming knife. (13-2)
 - (5) Return position of the movable trimming knife. (13-2)

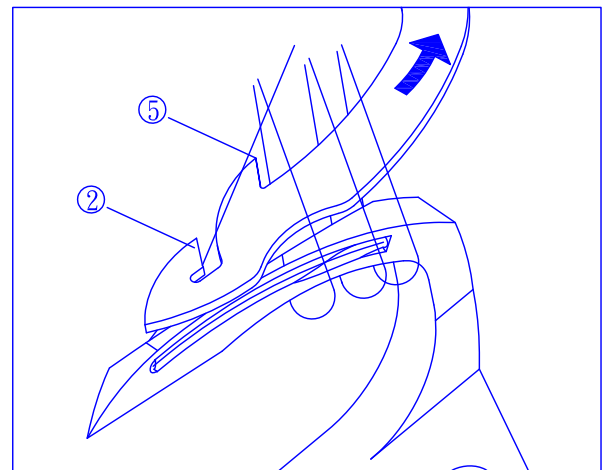
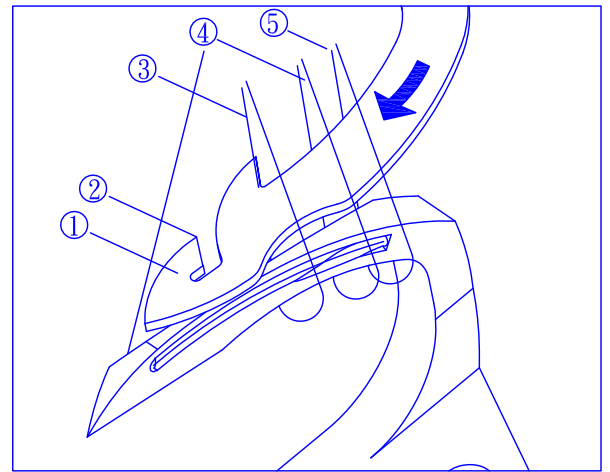

13-3 針線打線機構 Tension release mechanism

13-3-1 針線線頭長短的調整(圖091, 092) Tension release of needle thread

針線線頭長短的調整(圖091, 092)

鬆開螺絲③調整撥線桿①在最低點時與導線過線架②的上緣表面距離為5mm(圖091)(出廠標準)

針線的線頭長度, 導線支柱⑤的前端與底板②的前緣對齊, 是出廠標準(圖93)

*移動導線支柱⑤往S的方向, 線頭變短。(圖093)

*移動導線支柱⑤往L的方向, 線頭變長。(圖093)

Needle thread pull-off(rear) (091,092)

Loosen the screw ③ to adjust the distance between needle thread pull-off (rear) ① and upper surface of thread pull-off eyelet bracket ② to 5 mm (091) when the needle thread is loosened.

Amount of needle thread remainder

Align the front end of thread pull-off eyelet ⑤ with the tip of thread pull-off eyelet bracket ② as standard. (093)

* To decrease the needle thread remainder length, move it ⑤ in the direction "S" (093)

* To increase the needle thread remainder length, move it ⑤ in the direction "L" (093)

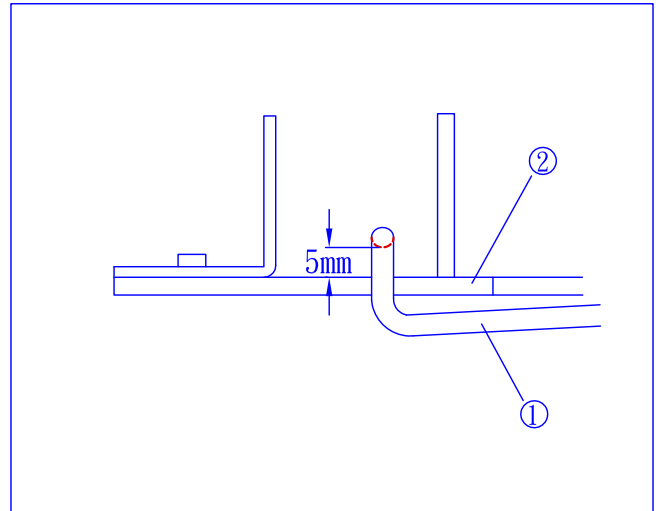

091

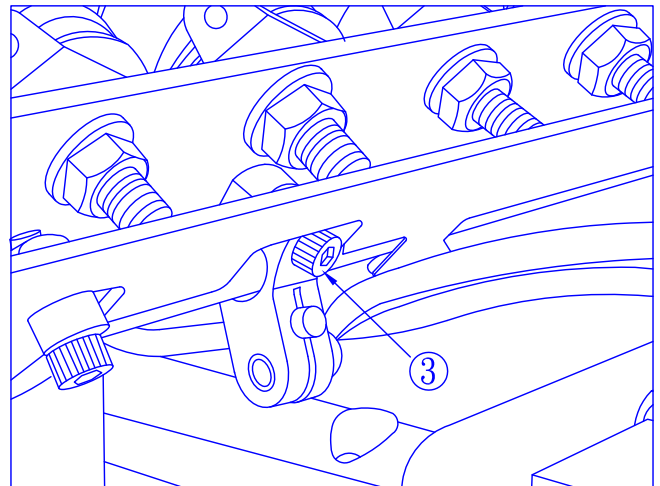

092

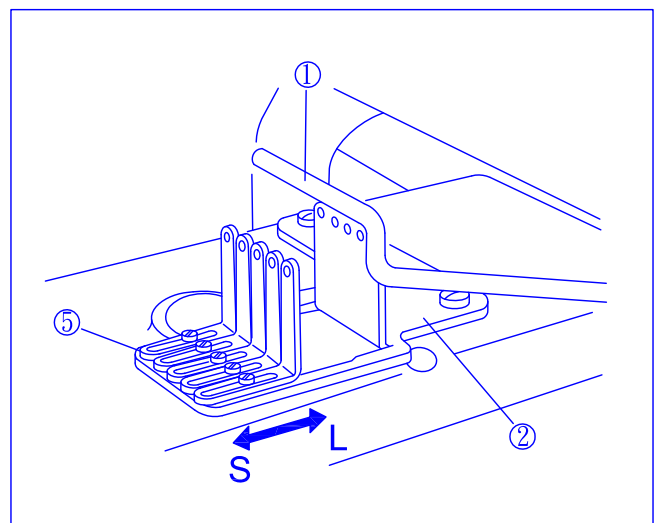

093

13-4 下勾針線的鬆線裝置 Tension release of looper thread

調下勾針切線後的長度讓下勾針線能夾住不脫落為原則
請鬆開螺絲①和②作下勾針切線後的長度調整。

Loosen screw ① and ② to adjust the remainder length of the looper thread as long as it can be successfully caught.

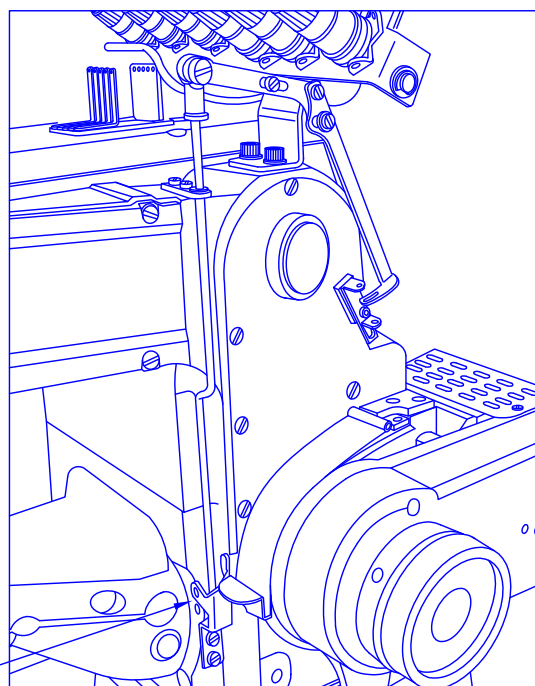
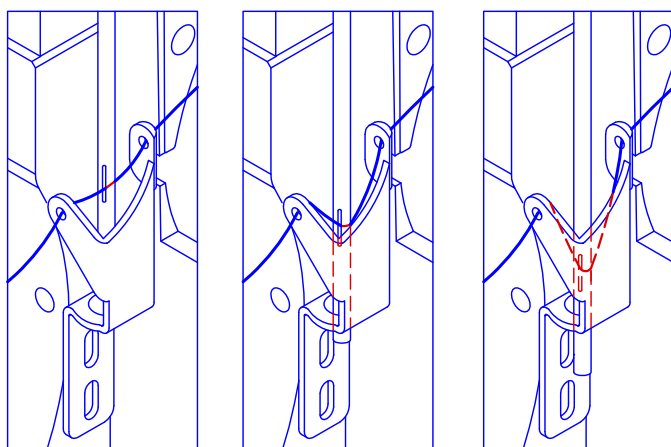

094

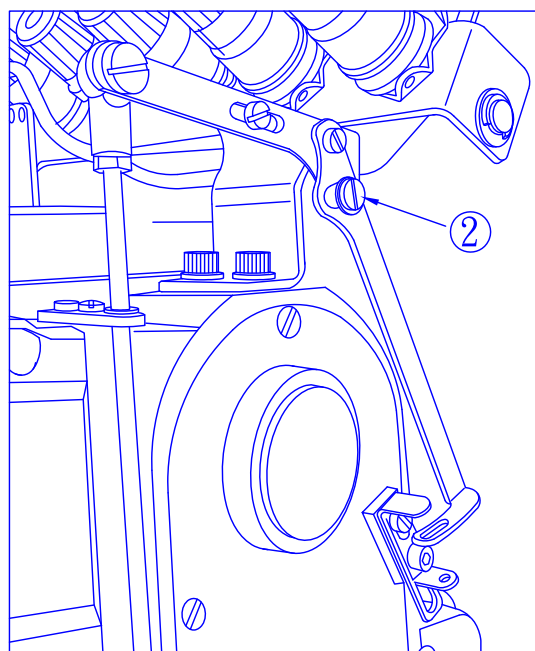

095

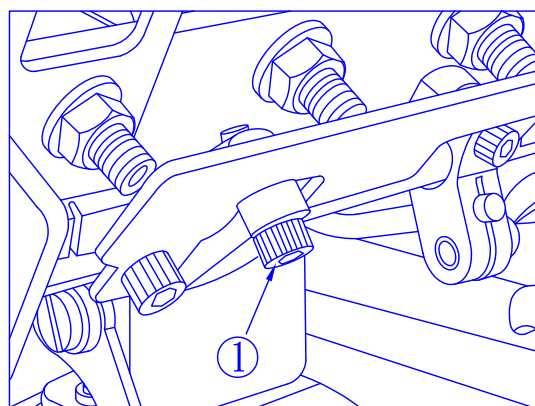

096



警示 WARNING

馬達開關要再OFF的位置並且要確認馬達已停止轉動
ALWAYS turn the motor switch OFF and check that
the motor has been already stopped.

13-5 抬押腳的機構 Presser foot lifter mechanism

- (1) 鬆開螺母 ①
- (2) 旋轉氣缸桿提升帽 ③ 使氣缸桿 ② 在最低點押腳下緣與針板表面間隙為8mm。
- (3) 鎖緊螺母 ①

- (1) Loosen the lock nut ①.
- (2) Turn the cylinder rod chip ③ to raise the presser foot by 8 mm when the cylinder rod ② is lower (when the cylinder operates).
- (3) Tighten the lock nut ① securely.

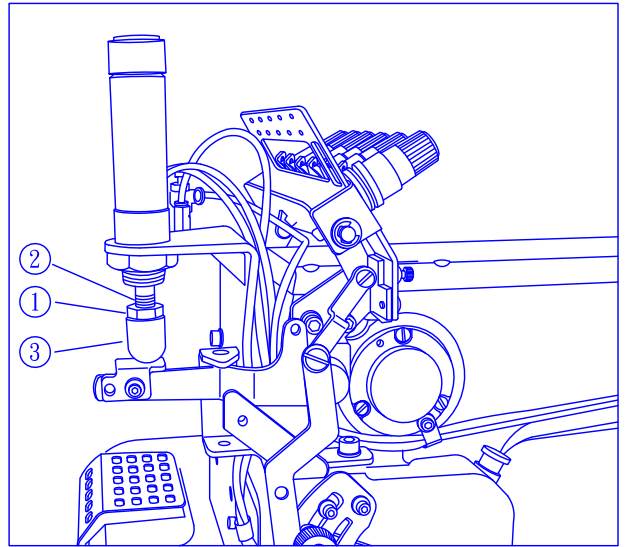

097



警告 WARNING

請關閉電源並且檢查馬達是否完全停止

ALWAYS turn the motor switch OFF and check that the motor has been already stopped.

13-6 上切線刀 Top Trimmer

13-6-1 活動刀的位置 Positon of movable trimming knife

- (1)當針在最高點時調整手輪①上的圓孔與記號②對齊。
- (2)用紗夾插入孔④並調整活動刀③在最低點
- (1)Set the mark ② on the machine arm at the scale marked of the handwheel ① (the needle is at the highest point).
- (2)set the movable trimming knife ③ to the lowerest point by inserting a pair of tweezes into the hole ④.



注意 CAUTION

不可讓活動刀③碰撞到押腳,左針⑤和上勾針⑥如果有發生此現象,請鬆開螺絲⑦和⑧作調整。

Never let the movable trimming knife ③ touch the presser foot, the left needle ⑤, and the spreader ⑥.

If touches, loosen the screw ⑦ and ⑧ to make adjustment.

- (3)鬆開螺絲⑩調整針板表面與活動刀在最低點時,刀口的尖點⑨與針板表面有6.5mm~7.0mm
- (4)作以上調整後,活動刀③必須越過上飾線,然後鎖緊螺絲⑦⑧和⑩
- (5)用手工動上下移動活動刀再次檢查其行程是否正確。
- (3)Loosen the screw ⑩. Make the clearance between the top of the stitch plate and the movable trimming knife tip to 6.5 - 7.0 mm when the movable trimming knife ⑨ is at the lowest point.
- (4)After adjusting above, the movable trimming knife ③ should be crossed over the top cover thread. Fasten screw ⑦⑧ and ⑩ .
- (5)Check the position of the movable trimming knife with moving it up or down.

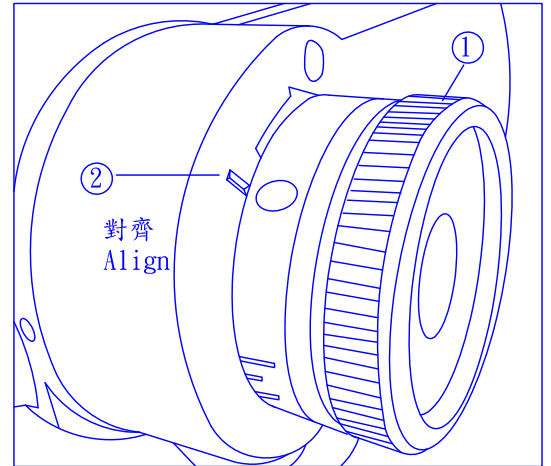

098

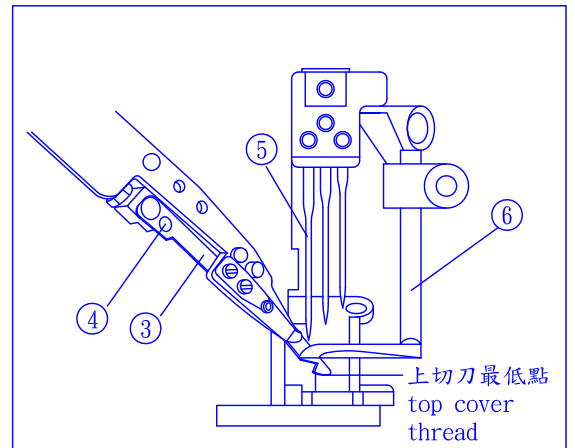

099

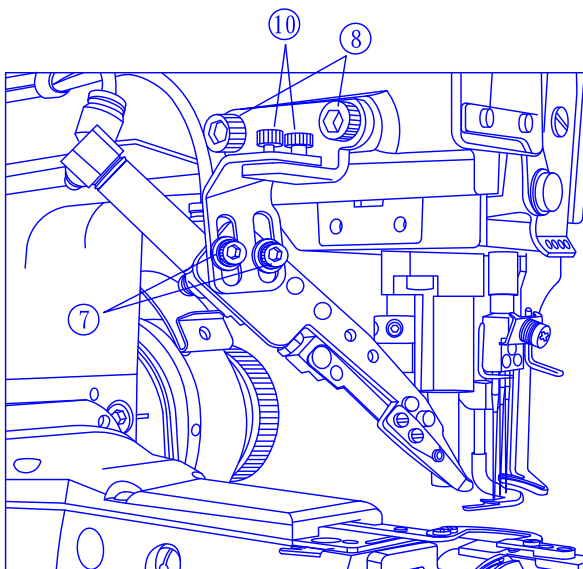

100

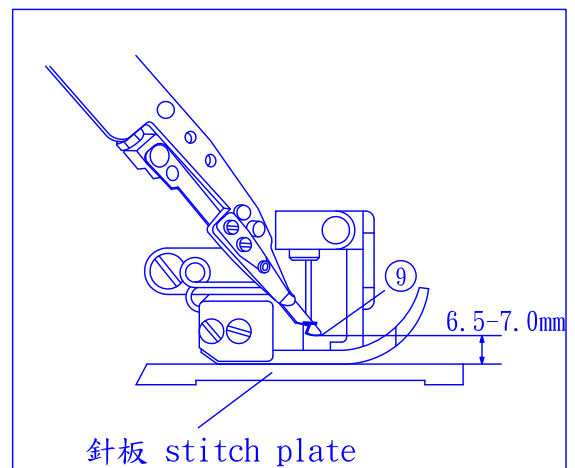

101

注意 NOTE

鬆開螺母①後旋轉螺絲②來調整活動刀線的速度

*順時針方向旋轉螺絲②切線速度變慢

*逆時針方向旋轉螺絲②切線速度變快

在活動刀切上飾線後押腳會開始提昇,要調整適當的切線速度,活動刀才不會碰撞到押腳。

To adjust the speed of the movable trimming knife, loosen the nuts ① and turn the adjusting screw ② on the speed controllers of the air cylinder.

●To speed down, turn them clockwise. ②

●To speed up, turn them counterclockwise. ②

The presser foot starts rising immediately after cutting the top cover thread with the movable trimming knife. Adjust the speed so that the movable trimming knife does not touch the presser foot.

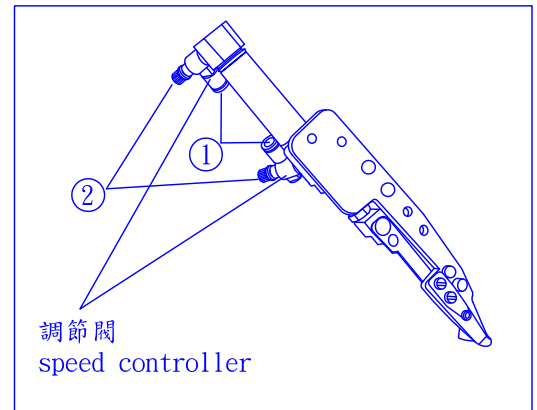

102

13-6-2 活動刀和固定刀之間的齒合度(圖103) Engagement between movable and fixed trimming knives 103



警示 WARNING

請關閉電源並且檢查馬達是否完全停止

ALWAYS turn the motor switch OFF and check that the motor has been already stopped.

活動刀的刀口尖點③與固定刀刀口④上緣約0~0.5mm的距離通常不需要作以上調整。(圖103)

the engagement between the movable trimming knife ③ and the fixed trimming knife ④ has been adjusted as shown in 103. Normally adjustment above is unnecessary.

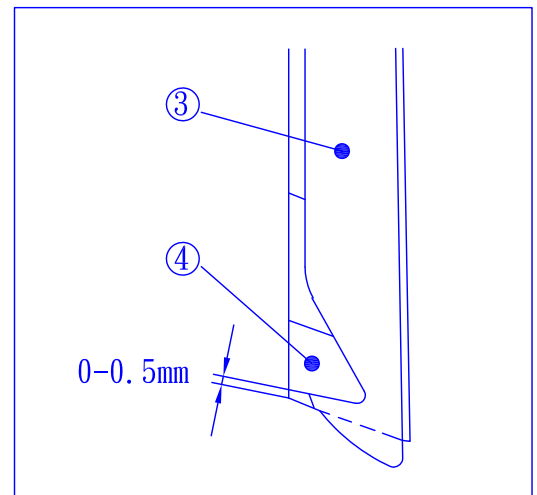

103



補充說明 Supplement

活動刀及汽缸的行程相同

The stroke of the movable trimming knife is the same as that of the air cylinder.



警告 WARNING

請關閉電源及確認馬達已完全停止運轉
 ALWAYS turn the motor switch OFF and check that the motor has been already stopped.

13-6-3 上切刀夾線彈片的壓力(圖104) Pressure of thread clamp spring

只要能夾住線頭, 夾線彈片壓力愈小愈好。
 調整螺絲③使夾線彈片②和活動刀①在切線後能夾住線頭
 旋轉螺絲③順時針方向, 夾線壓刀會增加
 Keep the pressure as low as possible to hold the threads.
 Loosen the nut③.
 Adjust the pressure with adjusting screw③ so that the thread clamp spring② and the movable trimming knife① can hold the threads after they are cut by the knife.
 To increase the pressure, turn the adjusting screw③ clockwise.

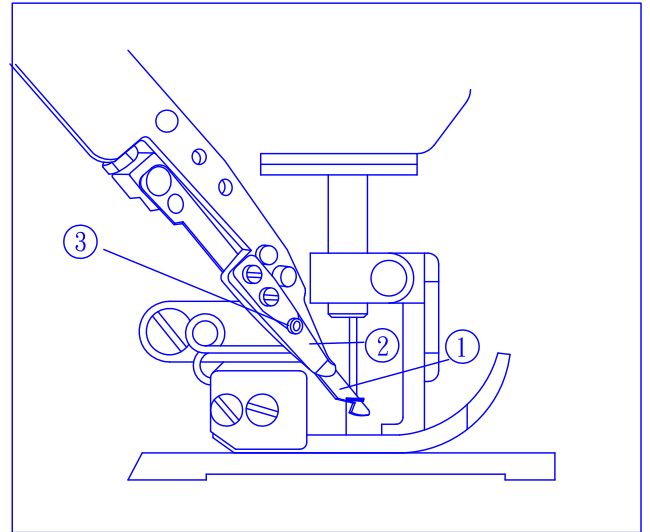

104

13-7 上飾線線頭長短的調整(圖105) Adjusting thread pull-off hook unit

- *移動導線支柱⑤往L方向, 線量會增加
- *移動導線支柱⑤往S方向, 線量會減少
- * to increase the thread remainder length, move the thread take-up ⑤ in the direction "L"
- * to decrease the thread remainder length, move the thread take-up ⑤ in the direction "S"

注意 NOTE

上飾線線頭的長度儘可能多留一點, 否則切線後無法有效夾線
 The thread remainder length should be kept as much as possible. If not, the top cover thread cannot be held after cutting.

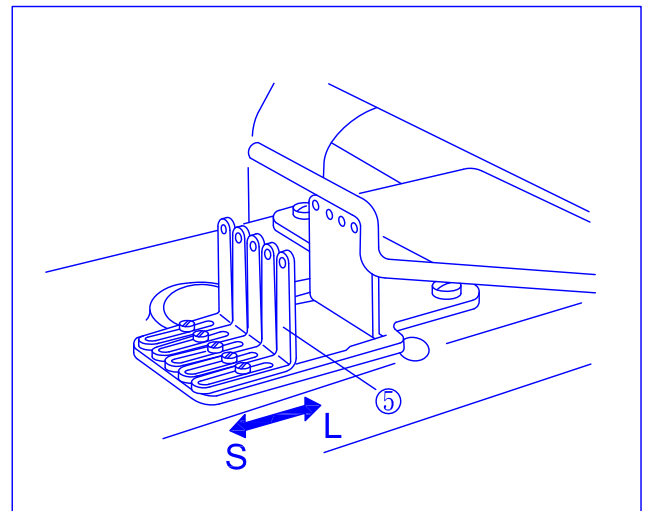

105

13-8 定期保養 Regular maintenance

3.5 定期保養

請定期把皮帶蓋①拆開，清理皮帶④與皮帶輪⑤和⑥內的灰塵及布屑清理乾淨以免皮帶造成損壞。

3.5 Regular maintenance

Remove the belt cover 1 to clean around it once a month. ①

Clogged dust between the timing pulleys ④ and the timing belt ⑤, ⑥ can cause the belt breakage.

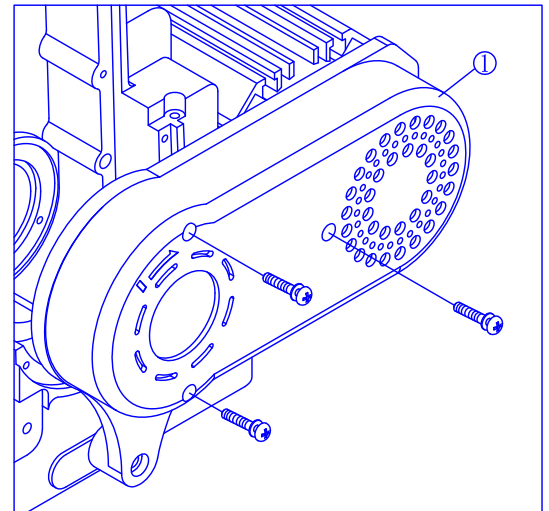

106



注意 CAUTION

卡在皮帶輪⑤，⑥和皮帶④之間的灰塵及棉屑會造成皮帶損壞
Clogged dust between the timing pulleys ⑤, ⑥ and the timing belt ④ can cause the belt breakage.

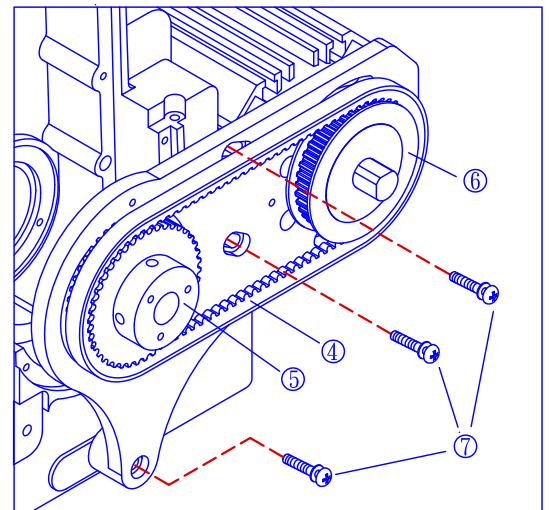

107



注意 CAUTION

拆卸前請先將連接線拔掉以避免損傷
Unplug all the intermediate cables which are connected to the solenoid valves. If not they may be scratched by moving parts and be damaged.

鬆開固定座三個螺絲⑦，可調整皮帶鬆緊及更換皮帶。
Loose the three screws on base to adjust the tension of the belt or belt replacement.

SL-703-GX-452/460/DS/PLA/VD

4-needle 6-thread feed-off-the-arm Interlock Flatseaming Machine with dual differential feed ratio regulator
手臂型四針六線併縫機(附雙差動送布齒裝置)



SL-2700-AST/EST

Feed-up-the-arm Interlock Machine with Compact Servo Motor and Thread Trimmer
縱筒型三針五線雙面飾綉縫機



SL-2800-356/SM

Feed-up-the-arm Interlock Machine with Compact Servo Motor and Thread Trimmer
縱筒型三針五線雙面飾綉縫機



VG-999ES-AST-TF-DS

Extremely-Small Cylinder-bed Interlock Machine with Thread Trimmer and Top Feeder
超細筒型三針五線雙面飾綉縫機

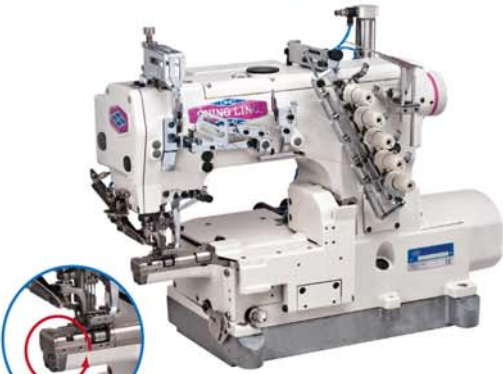

VG-888S-TF-AST

Small Cylinder-bed Interlock Machine with Thread Trimmer and Top Feeder
細筒型三針五線雙面飾綉縫機(附上送裝置)



VG-888A-TF/AST

Top Feeder for 3-needle 5-thread Cylinder-bed Interlock Machine
橫筒型三針五線雙面飾綉縫機(附上送裝置)



VG-999S-N700-AST-TF-DS

Small Cylinder-bed Interlock Machine with Left-hand Knife and Top Feeder for Hemming
細筒型三針五線雙面飾綉縫機(附左修刀)



VG-888A-N600-TF/AST

Interlock Machine with Left-hand Knife and Thread Trimmer for Hemming
橫筒型附左修刀雙面飾綉縫機



SL-1790S

Computer-controlled High-speed Lockstitch Buttonholing Machine
高速電子平頭鎖眼機



VG-999-SB-AST/EST-DS

High-speed Short Cylinder-bed Interlock Machine with Thread Trimmer
短筒型三針五線雙面飾綉縫機



VG-999-R500-AST-RP

Interlock Machine with Right-hand Knife and Rear Puller for Elastic Waistband Attaching
高速橫筒型三針五線附右修刀雙面飾綉縫機



VG-999-356/EST/DS/ZBR

Dual Colors Decorative Stitches Interlock Machine with Top and Under Thread Trimmer
高速橫筒型三針五線雙色上飾綉縫機

