

SINCE 1989

SHING LING®

星菱牌工業用縫紉機

INDUSTRIAL SEWING MACHINE



百分之百台灣製造
100% Made in Taiwan



台正字第8144號



TAIWAN
EXCELLENCE 2012

VG-898A Series

新型高速三針五線氣動式自動切線摺下擺綳縫機

Newly-developed High-speed 3-needle 5-thread Cylinder-bed
Interlock Machine with Pneumatic Top and Under Thread Trimmer

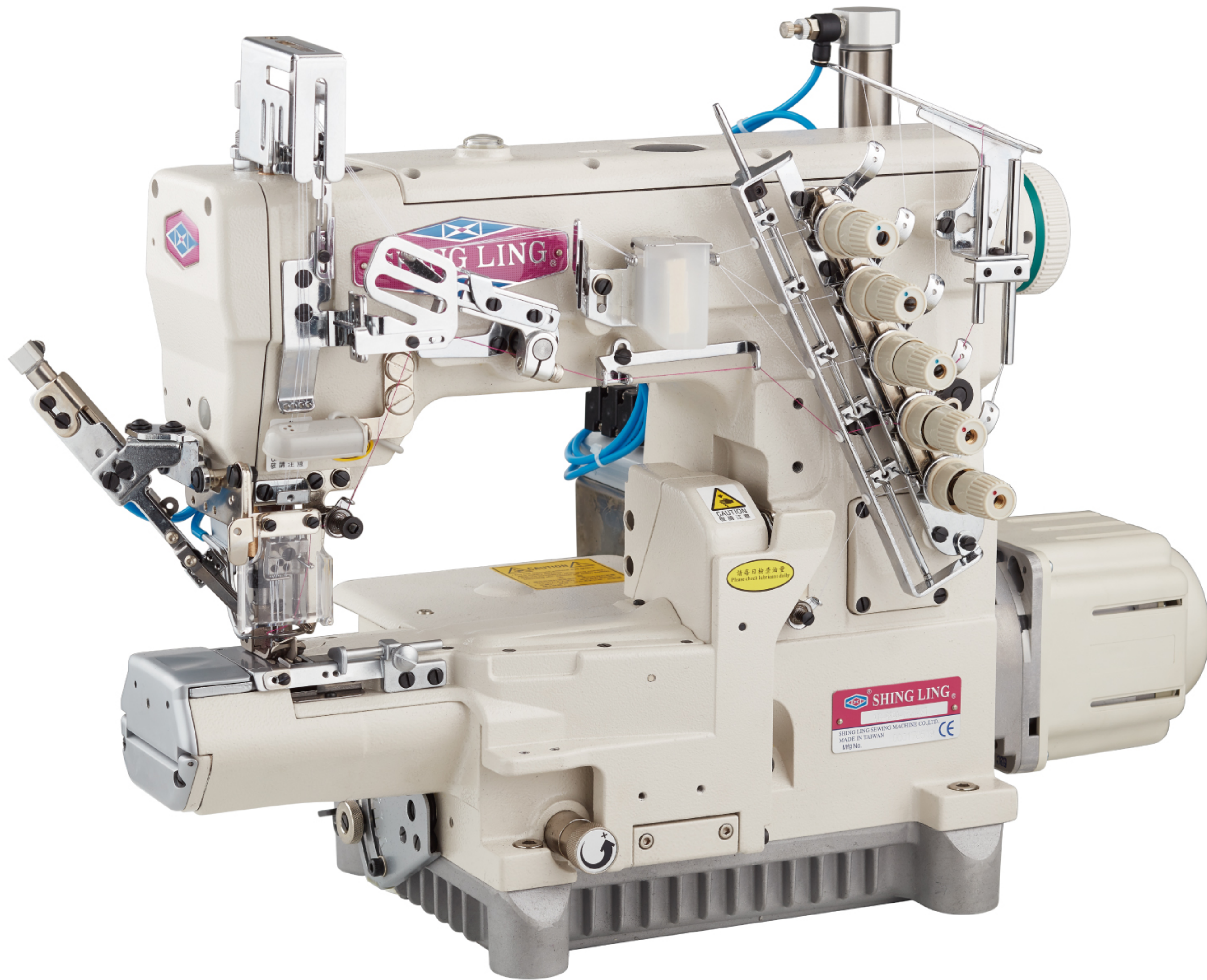

使用說明書 Instruction Book



SINCE 1989

星菱縫機股份有限公司

SHING LING SEWING MACHINE CO., LTD.

CE ISO 9001/CNS 12681



INDEX

索引

OPERATION GUIDE

- A、INSTALLATION
- B、MOTOR AND BELT
- C、LUBRICATION OIL
- D、CHANGE OF LUBRICATING OIL
- E、REPLACING OIL FILTER
- F、HOW TO REPLACE THE NEEDLES
- G、THREADING
- H、ADJUSTING THREAD TENSION
- I、ADJUSTING THE NEEDLE THREAD EYELET
- J、ADJUSTING OF TOP COVER THREAD EYELET
- K、ADJUSTING PRESSER FOOT
- L、ADJUSTING THE PRESSURE OF PRSSER FOOT
- M、ADJUSTING STITCH LENGTH
- N、ADJUSTING DIFFERENTIAL FEED RATIO

ADJUSTMENT GUIDE

- A、ADJUSTING THE HEIGHT OF NEEDLE BAR
- B、POSITION OF NEEDLE AND LOOPER
- C、ADJUSTING TIMING RELATION BETWEEN NEEDLES AND LOOPER
- D、ADJUSTING THE HEIGHT OF REAR NEEDLE GUARD
- E、ADJUSTING FRONT AND REAR NEEDLE GUARD
- F、ADJUSTING THE HEIGHT OF FEED DOG
- G、ADJUSTING THE POSITION OF THE SPREADER
- H、FIXING OF TOP COVER THREAD GUIDE & TOP COVER THREAD EYELET
- I、THE POSITION OF LOOPER THREAD TAKE-UP
- J、ADJUSTING SAFETY SWITCH
- TABLE TOP INSTALLATION

一、使用說明

- | | PAGE/頁 |
|--------------|--------|
| A、安裝 | 1 |
| B、馬達與皮帶 | 2 |
| C、潤滑油 | 3 |
| D、潤滑油的更換 | |
| E、濾油器之更換 | 4 |
| F、擊針的選用及更換方式 | |
| G、穿線方式 | 5 |
| H、拉線鬆緊度的調整 | 6 |
| I、針線過線桿的調整 | |
| J、上飾線控線桿的調整 | |
| K、押腳的調整 | 7 |
| L、押腳壓力強度的調整 | |
| M、縫目長度的調整 | |
| N、差動比的調整 | 8 |

二、調整說明

- | | |
|---------------|----|
| A、針棒高度的調整 | 9 |
| B、針與勾針位置的說明 | |
| C、針與勾針的時位關係調整 | 10 |
| D、頂針片高度之調整 | 12 |
| E、前後頂針片之調整 | 13 |
| F、送布齒高度的調整 | 14 |
| G、上叉位置的設定 | |
| H、上飾線之導線器的固定 | 15 |
| I、勾針控制線桿的位置 | 16 |
| J、安全閥調整 | |
| 一般桌板圖 | 17 |

一、使用說明:

OPERATION GUIDE

A. 安裝：

INSTALLATION:

1. 請依本機器所附之各式桌板裁製圖，根據實際上之需求，裁製正確桌板。

Before installing machine, please refer to table cut-out drawing to cut out table correctly.

2. 再依序安裝防震膠墊，或支撐架及其他副件。

According to the sequence of installation, fix quake-proof, base-fixed plate and other attachments.

* 注意：

Remarks :

- (1) 一般桌板 -

請依下圖所示順序安裝膠墊支架及防震膠墊。(圖1)

General table -

According to the sequence of Fig.1, install quake-proof Rubber Cushion and the frame of the Cushion.(Fig. 1)

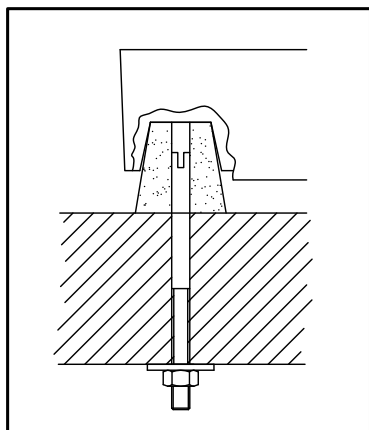

(Fig. 1)

(離合器一)安裝注意事項方法

3. 馬達之轉向為順時鐘方向，皮帶之鬆緊度以用手指向內壓 2 cm 為一般標準，同時為了安全起見，請將上、下皮帶蓋蓋上。(圖2)

Be sure that the Motor turning direction is clockwise, and the Motor Belt tension can be pressed with finger inward 2cm. For safety reason, please fasten the Belt Cover. (Fig. 2)

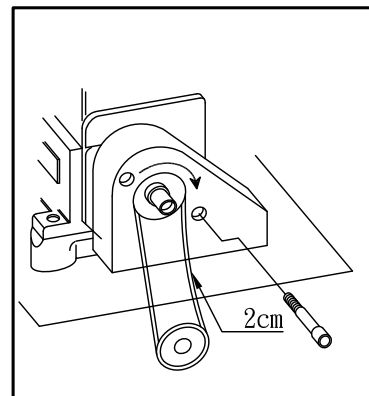

(Fig. 2)

4. 皮帶輪相對轉速與皮帶尺寸請參照表1。

本機最高的車縫速度為每分鐘6,000轉，一般轉速為每分鐘5,500轉(於裝上皮帶輪後，最高轉速為4500轉，一般轉速為4000轉)。為了提高機台使用壽命，新機於開始使用的前200小時(約1個月)內，其轉速切勿超過每分鐘5000轉。(圖4)驅動輪與皮帶軸之轉向皆為順時鐘方向。

For machine's long-life and durable operation, it is recommended that the maximum speed shouldn't exceed 80% of the speed listed on Table 1. Make sure to choose the correct size of Motor Pulley and Belt.

The turning direction of Pulley (A) is clockwise like Handwheel (B). (Fig. 4)

Table 1(表1)

Machine speed (s.p.m.) 轉速/分	Motor pulley Outer Diameter(mm)		Motor Belt V-BELT,M-TYPE (CLUTCH MOTOR)
	60HZ	50HZ	
6,000	105	125	36"
5,500	95	115	↑ 35"
5,000	85	105	↓ 34"
4,500	80	95	
4,000	70	85	

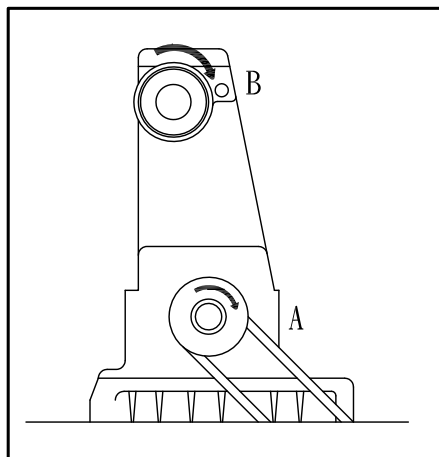

(Fig. 4)

B.馬達與皮帶:

MOTOR AND BELT :

1. 請依照表1所指示之規格安裝馬達，並使用M番之V型皮帶。

安裝馬達時，馬達驅動輪與機器皮帶輪之中心點須呈一直線。而在使用離合器馬達時，所謂馬達驅動輪與機器皮帶輪之中心點呈一直線，是指離合器馬達驅動輪，因起動踏板下踩而向左靠列底的狀態下。(圖5)

Use Clutch Motor and V-Belt of M-type. Position Motor so that its center aligns with the center of machine's Pulley when the Pulley is shifted to the left by treading Pedal. (Fig. 5)

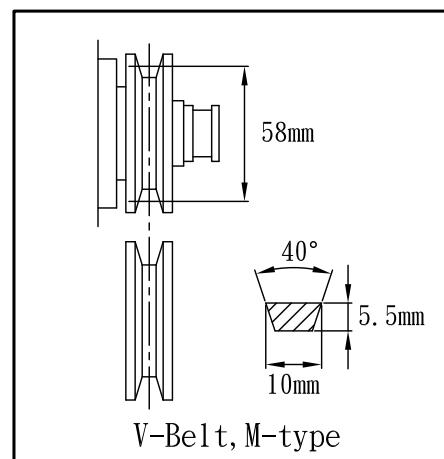

(Fig. 5)

C. 潤滑油: LUBRICATION OIL:

1. 請選用與 Mobil #10或 Esso #32 同級之潤滑油。

Please use oil Mobil #10, Esso #32 or its equivalent .

2. 在新機使用前請先注入潤滑油。撥開 (圖 5-A)頂蓋，將油緩緩注入機器中，待油滿至油量指示窗 (A) 上下線之間即可。(圖 6-A)

As the oil has been completely drained before shipment, please fill lubrication oil first before the new machine to be used.

To remove Oil Sight Window Plug (A) and fill the oil slowly until the oil level reach between lines H and L of Sight Gauge B. (Fig. 6)

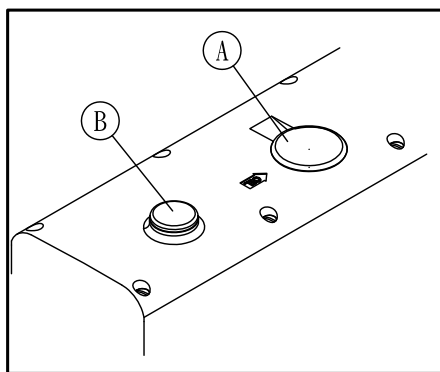

(Fig. 6)

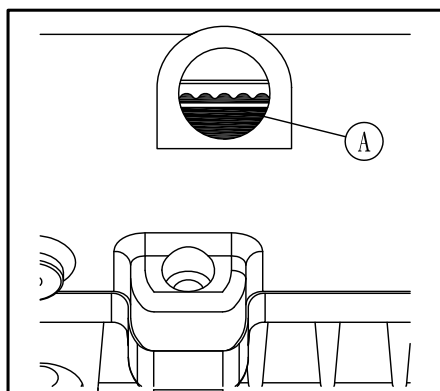

(Fig. 6-1)

3. 於每天開機操作時，請先檢查噴油狀態 (圖 6-1) (B) 是否正常且注意油量是否低於指示窗之下限，若低於下限請隨時補充新油。

When you begin operating the machine, please check whether all the lubricating system is in good condition.

If oil is lower under L line of Oil Sight Gauge B, please supply oil. (Fig.6-1)

D. 潤滑油的更換: CHANGE OF LUBRICATING OIL:

1. 為延長本機的使用壽命，請於開始使用後的一個月內更換第一次新油，以後約每六個月更換一次。
更換潤滑油時，請先取下V型皮帶，再將機器自工作檯取下。先卸下放油螺絲 (A)，並倒乾油槽內之舊油，此時，注意勿污染V型皮帶。待舊油完全排出後，再將放油螺絲鎖緊，再依 C-2 的步驟注入新油。(圖 7)

For machine long-life and durable performance, please replenish lubricating oil after one-month operation and it must be completely changed every six months thereafter.

Please remove V-belt from Pulley and remove machine from Table. After removing Screw A, draining all the used oil from the Reservoir.

When you replenish new oil, take care not to smear V-Belt with oil then tighten Screw without fail. (Fig. 7)

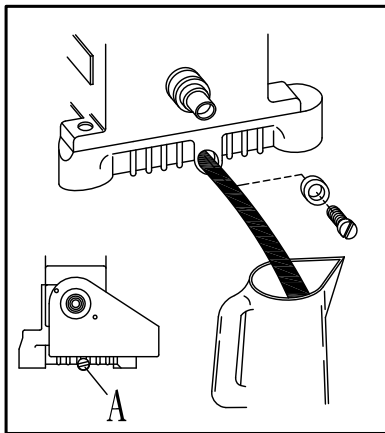

(Fig. 7)

E. 濾油器之更換:

REPLACING OIL FILTER :

本機裝有濾油器，新機使用一個月後必須更換新品。此後，約每 6 個月更換一次。(圖 8)

The machine is equipped with an Oil Filter as Fig. 8, when Oil Filter gets clogged with dirt, the proper lubrication is impossible.

Therefore, please change Oil Filter after one month initial operation and please change Oil Filter every six months thereafter. (Fig. 8)

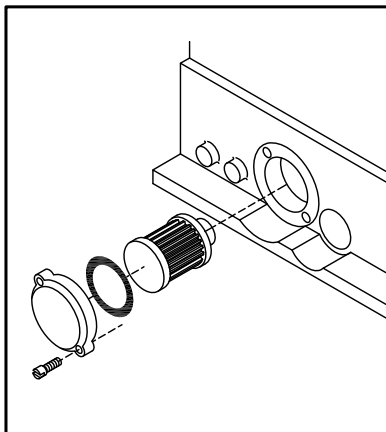

(Fig. 8)

F. 擊針的選用及更換方式:

HOW TO REPLACE THE NEEDLES :

1. 本機使用編號 UY/128GAS 的各式大、小番號擊針或其他相同規格之產品。

Please use all kinds of the model number UY/128 GAS of Organ's needle or its equivalent.

2. 在更換擊針時，請先旋開鎖針螺絲 (A)，並取下舊針，再依車縫布料厚薄、質料，選定最合適之擊針，將新針插至針鐳之最頂端，且使長溝面背向自己。(圖9)

When replacing new needles, loosen Screw A, then pull out the used needles, insert the new ones into the hole of Needle Holder as far as they can go and adjust the Needle Scarf facing rearwards from operator's view. (Fig. 9)

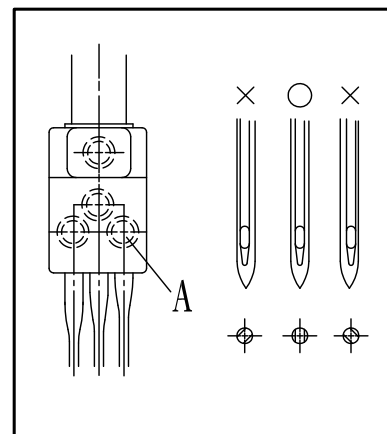

(Fig. 9)

3. 重新將鎖針螺絲鎖緊 (A)。
Fasten screw (A).

G. 穿線方式:

THREADING :

1. 請按照圖中所指示的穿線方式，正確穿線。若穿線方式錯誤，將會引起斷線，跳針或車縫不平坦等現象。
(圖10)

Please refer to Fig. 10 for threading.

Wrong threading may cause thread breakage, stitch skipping, puckering, uneven seam, ect.

2. A.B.C……擊針線，
D……上裝飾線，
E……下勾針線。(圖10)

A.B.C……are needle threads,
D……is top covering thread,
E……is looper thread.

3. 若用三針車縫，則穿線方式如圖所示。
若用二針車縫，穿線方式亦相同，所不者，僅是擊針線穿二針而已。
(圖10)

The illustration Fig. 10 Shows the threading for 3-Needle Machine.

When cotton or nylon threads is used as looper thread, The thread should go through Fig. 10-a as shown.

4. 當下勾針線使用棉線或伸縮尼龍線時，其穿線方法並不相同，請參照圖 10-a 中的正確方式穿線。

When woolly, nylon or similar thread is used as Looper thread, please refer to Fig 10-a for threading.

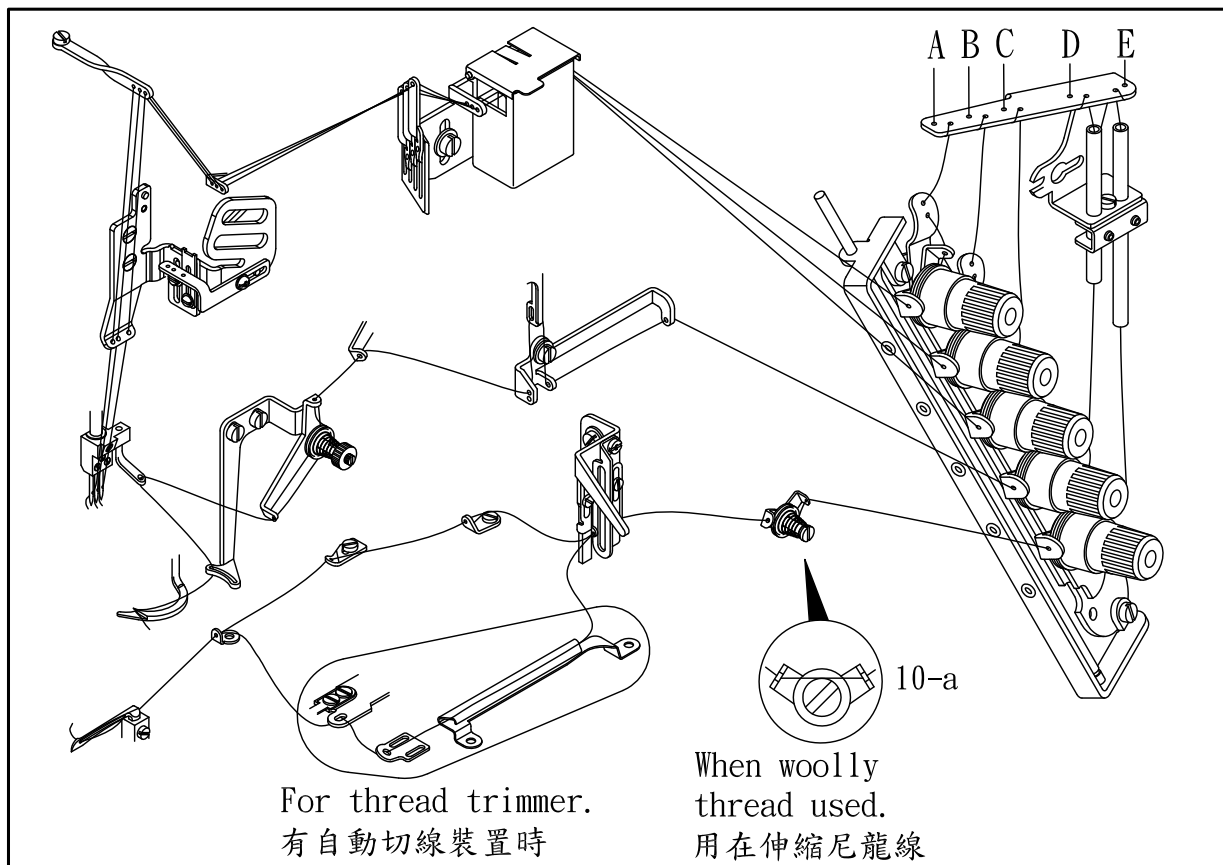

(Fig. 10)

H. 拉線鬆緊度的調整:

ADJUSTING THREAD TENSION :

拉線的強弱必須根據車縫的布料、厚薄及線與針距的不同，而做調整，將針線控制鈕順時鐘方向旋轉時，線愈緊，反之則愈鬆。

The tension of the thread depends on

1. The material and the thickness of the fabric to be sewn;
2. The threads to be used.
3. The stitch width, stitch length, etc.

If you turn the Thread Tension Spring Cap clockwise, thread will be tighter, on contrary, it will be looser.

Make the thread tension as weak as possible according to the sewing condition as long as stable seam can be obtained.

I. 針線過線桿的調整:

ADJUSTING THE NEEDLE THREAD EYELET :

1. 當針棒降至最低時，針線提線過線桿與桌面平行。(圖 11)

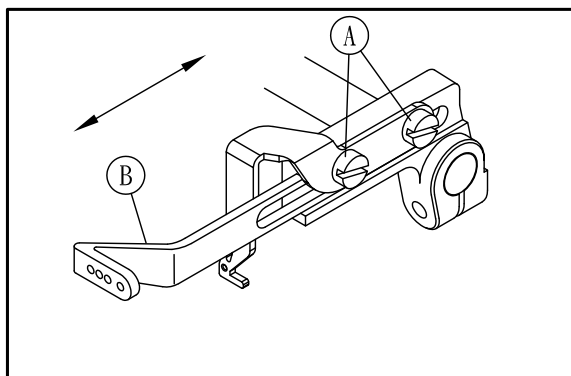

(Fig. 11)

2. 本機的針線提線過線桿 (A) 上有六個刻度，本機於出廠時皆將針線提線過線桿上由右至左算起的第四個刻度對準托架 (C) 右端，再連同上飾線提線過線桿一齊鎖在托架上。
3. 欲將針線調緊些，可將針線提線桿 (B) 向右方移動，反之則可將針線調鬆些，鬆開 2 個螺絲 (A) 做以上調整。

When the Needle Bar down to the lowest position, the Needle Thread Tension level (B) should remain horizontal.

To make the needle threads tighter, please move the Needle Thread Tension Level (B) to right. On contrary, it will make the needle threads looser when moving to left. To adjust it by loosening two screws (A).

(Fig. 11)

J. 上飾線控線桿的調整:

ADJUSTING OF TOP COVER THREAD EYELET :

1. 除針線控制鈕可調整上飾線之張力外，上飾線過線桿 (1) 亦可調整上飾線之鬆緊 (圖 12)，鬆開固定螺絲 (2)，將上飾線過線桿往下移，可將上飾線放鬆，反之則可將上飾線收緊。
2. 當針線控線桿向左下方傾斜大一點，則可將上飾線放鬆，反之則可將上線收緊。

The tension of top cover thread also can be adjusted by loosening Screw (2) then moving Top Cover Thread Eyelet upward or downward. (Fig. 12)

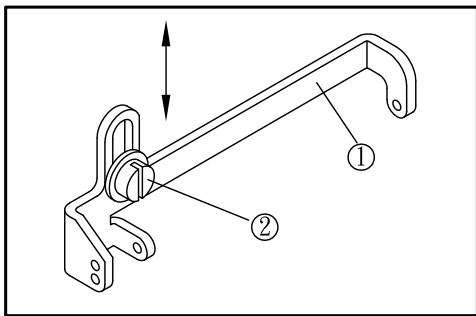

(Fig. 12)

K. 押腳的調整:

ADJUSTING PRESSER FOOT :

鬆開押腳固定螺絲①左右搖動，調整押腳，使針尖位於押腳針孔的正中央，調整好後，再將固定螺絲鎖緊。(圖 13)

Loosne Screw ① and adjust Presser Foot left and right to a proper position where the needles can get into the center of Presser Foot eyelets.

After adjusting, tighten Screw ①. (Fig. 13)

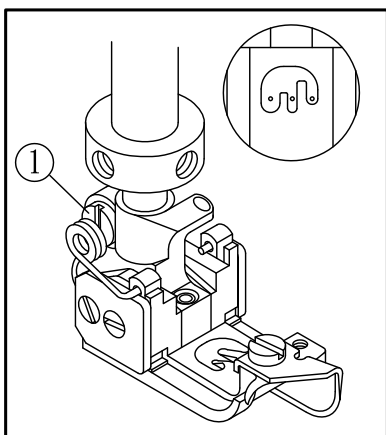

(Fig. 13)

L. 押腳壓力強度的調整:

ADJUSTING PRESSURE OF PRESSER FOOT :

1. 若要求布料車縫順暢且縫合完美，押腳壓力應儘量輕些。

Adjust Presser Foot pressure as weak as possible, so that cloth can be sewn smoothly.

2. 鬆開螺帽(A)，轉動螺絲(B)，待其調整至適當壓力後再將螺帽(A)鎖緊。(圖 14)

Loosen nut (A), turn screw (B) to a proper pressure, then fasten nut(A).

(Fig. 14)

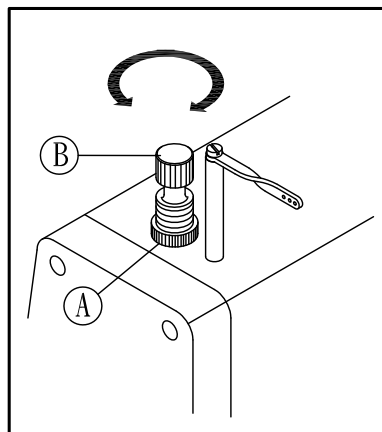

(Fig. 14)

M. 縫目長度的調整:

ADJUSTING STITCH LENGTH:

本機的標準縫目為最粗針 1 英吋約 7 針，最細針 1 英吋約 15 針，採用無階段式調整。

Stitch length can be adjusted in any range from 3.6mm~1.7mm or 7-15 stitches per inch.

1. 將針距調整鈕 順時鐘方向旋轉時，則縫目愈密，反之則縫目愈疏。(圖15)

Turn Knob①clockwise, the stitch length becomes short, on contrary, it becomes long. (Fig. 15)

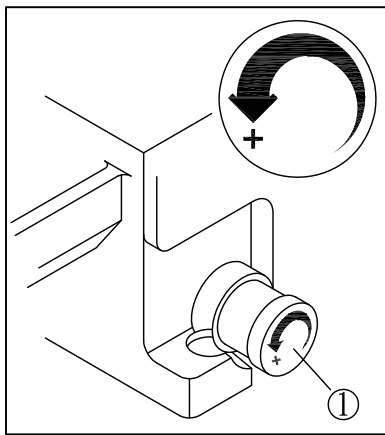

(Fig. 15)

2. 本機可於機器轉狀態下，旋轉針距調整鈕調整縫目長度，不須停機。

You can adjust the stitch length at ease when machine is being operated. There is no need to stop the machine.

N. 差動比的調整:

ADJUSTING DIFFERENTIAL FEED RATIO :

1. 本機之差動比可從1:1.7調整至1:5.6。

The differential feed ratio of this machine is adjustable from 1:1.7 to 1:5.6

2. 將圓筒上側蓋向左打開，用3mm之內六角扳手放鬆螺絲②上下移動即可調整差動比。(圖16)

Open the Upper Cylinder Side Cover and use 3 mm Hexagon Wrench to loosen the Screw②.

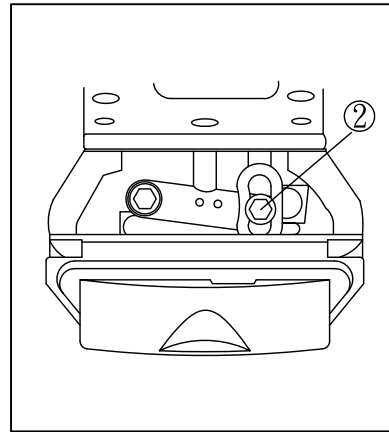

(Fig. 16)

3. 將差動驅動連桿往上移動時，則差動齒比主齒傳動速度快，可做摺景車縫，反之，則差動齒比主齒，傳動速度慢，可做伸展布料車縫使用。

Move the Differential Feed Bar upward, the ratio become large to gather the cloth . Move it downward, the ratio become small to stretch the cloth.

二、調整說明:

ADJUSTMENT GUIDE

A. 針棒高度的調整:

ADJUSTING THE HEIGHT OF NEEDLE BAR :

1. 當針棒移到最高點時，左針尖端與針板距離如附表 2，為針棒之標準高度。

When the Needle bar is on the top position, the distance between the Left Needle tip and Stitch Plate is shown on table 2 .

This is the standard height of Needle Bar.

#33 (Table 2.)

規格種類 Needle Gauge	左針高度(MM) Height of Left Needle
240	8.8
248	8.4
356	8.2
460	7.8
464	7.8

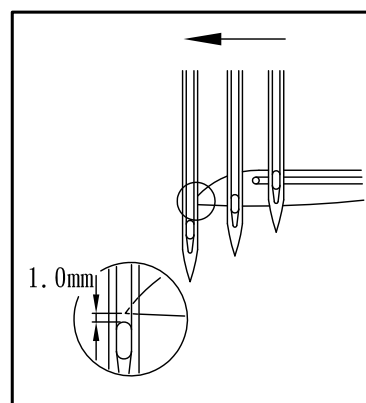
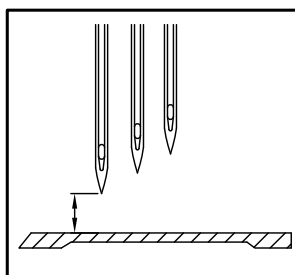

(Fig. 18)

2. 若要調整針棒高度，請取下止油膠蓋，放鬆針棒連桿 (A) 上的螺絲 (B)，上下調整針棒的高度後在固定之。
(圖 17)

To adjust the height of Needle Bar, remove the Rubber Seal Plug and loosen the Screw B of Needle Bar A, adjust the Needle Bar up or down to the required position and fix the Screw B .

(Fig. 17)

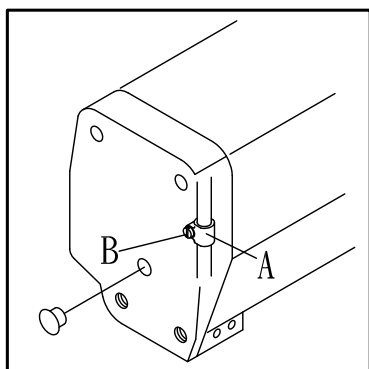

(Fig. 17)

3. 當下勾針向左前進與最長針 (左針) 對齊時，勾針針尖底部與針孔上沿距離 1mm，此一相對位置即為本機針棒之標準高度。(圖 18)

When the Loooper goes through the Left Needle, the Loooper tip is 1.0mm above the upper end of the Left Needle hole.

(Fig.18)

B. 針與勾針位置的說明:

POSITION OF NEEDLE AND LOOPER :

1. 將勾針固定於勾針座上，勾針約向前 (向操作者方向) 偏 0.4mm~0.5mm。
(圖 19)

Insert the Loooper into the Loooper Holder as far as it can go and deflect the Loooper to the front about 0.4mm ~ 0.5mm .

(Fig. 19)

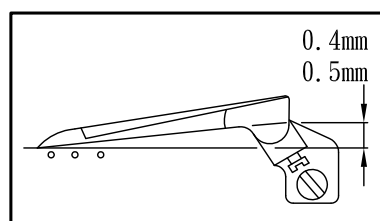

(Fig. 19)

2. 再將針棒降至最低，且下勾針退至右孔點，此時最短針(右針)與下勾針針尖的距離為 2.7mm ~2.8 mm、不同針距，請參照表 3 做調整。(圖 20)

To move the Needle Bar to the lowest position, at the same time, the Loper retruns to the extreme right end, the distance between Right Needle and the Loper tip is 2.7mm ~2.8mm . (Fig. 20)

Please refer Table 3 for other Needle gauge's adjustment

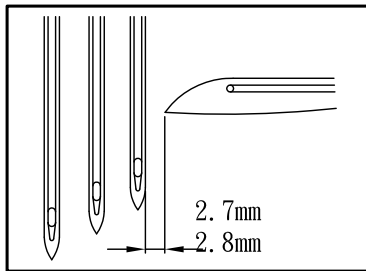

(Fig. 20)

* 注意:
NOTE :

經過調整後，必須確定每一根針是通過針板針孔的正中央。(圖 21)

Insert the Needles into the Holder as far as they can go.

After the adjustment, make sure the needles can get into the center of the Needle Plate holes, and the gaps are even. (Fig. 21)

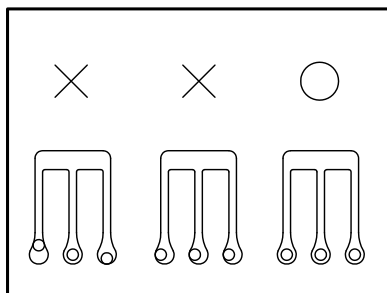

(Fig. 21)

C. 針與勾針的時位關係調整:

ADJUSTING TIMING RELATION BETWEEN NEEDLES AND LOOPER :

1. 當勾針向左前進通過右針時，勾針針尖與針應輕微接觸 0.03mm ~ 0.05mm 。(圖 22)

When the Loper moves from extreme right and forward to the Right Needle, the Loper tip shall slightly contact the Needle by 0.03 mm ~ 0.05mm.

(Fig. 22)

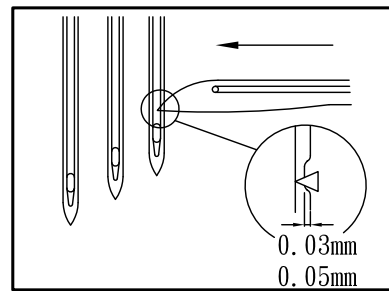

(Fig. 22)

2. 當勾針向左前進通過左針時，勾針針尖與針的距離為 0.15 ~ 0.20mm 。(圖 23)

When the Loper moves to the Left Needle, the clearance is about 0.15mm ~ 0.20mm.

(Fig. 23)

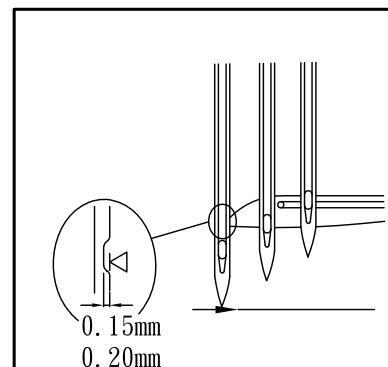

(Fig. 23)

3. 當勾針向右退後，左針必須插到勾針斜面積線往上 0.3mm ~ 0.4mm (如圖 24) 且當最長針針尖與勾針底部平齊時，勾針針孔中心到左針的距離 1.5mm ~ 2.0mm。
(圖 25)

When the Loper moves backward to Left Needle, the Left Needle tip should stick on the slant edge of the Loper by 0.3mm~0.4mm. (Fig. 24)

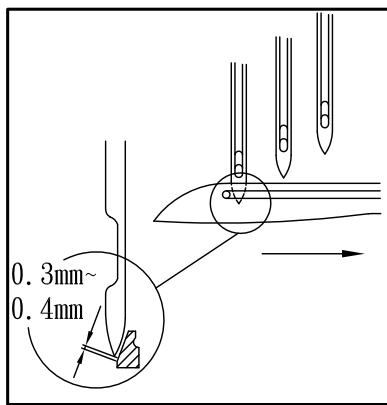

(Fig. 24)

When bottom surface of the Loper aligns with the tip of Left Needle, the distance from the center of Loper hole to Left Needle edge is about 1.5mm~2.0mm. (Fig. 25)

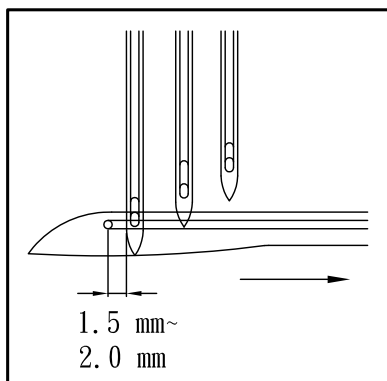

(Fig. 25)

* 注意：
Note :

若欲調整擊針插到勾針斜面之厚、薄，請先將縫製平台，曲軸室上蓋及曲軸室製墊片取下，再放鬆下勾針驅動軸導槽旁的搖臂調整鎖鎖上的螺絲 (A)，將螺絲往前 (操作者方向) 推動鎖緊，則擊針插到斜面之厚度減少，反之 (圖 25) 則愈來愈厚。

To adjust the left needle sticking on the looper slant edge (Fig. 24), please take off Crank Chamber Cover and Crank Chamber Gasket from the Cloth Plate by adjusting the Screw of Loper Bar Guide A .

Turn screw A to operator's direction to fasten, the sticking amount will be less on contrary, it becomes more.

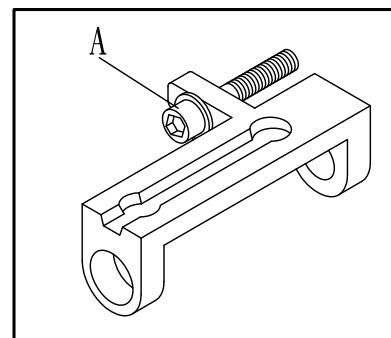

4. 當勾針向右退後經過中針時，此時勾針之針孔與中針的針孔成一線。
(圖 26)

When the Loper goes backward to the Middle Needle, the hole of the Loper shall align with the hole of the Middle Needle. (Fig. 26)

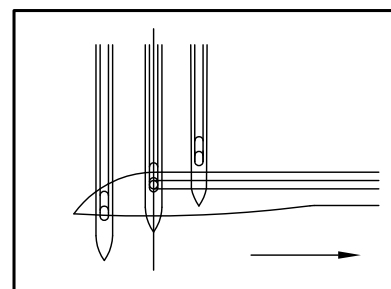

(Fig. 26)

*** 注意:**
NOTE :

若欲調整勾針運轉時間，請先將上蓋取下，放鬆上主軸鏈輪上的螺絲 (A)，另一手握住手推輪使其不動，此時將主軸鏈輪往前 (操作者方向) 推動，則勾針運轉時間延後，反之，則勾針時間提早。(圖 27)

To adjust the Loooper's movement, please open Top Cover and loosen the 4 Screws of Upper Shaft Sprocket (A) then hold Hand Wheel still.

When slightly turn Shaft Sprocket to operator's direction, the Loooper's movement will be delay, on the contrary, it will be expedised. (Fig. 27)

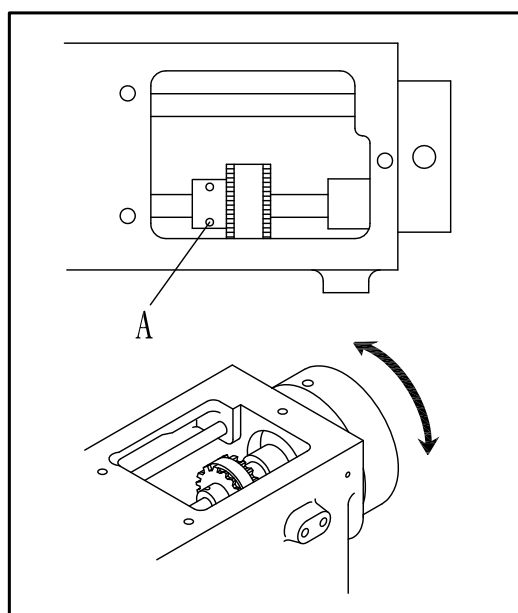

(Fig. 27)

D. 頂針片高度之調整:

**ADJUSTING THE HEIGHT
OF REAR NEEDLE GUARD :**

1. 當針棒降至最低時，後頂針片上之稜線 (A) 與之跟針之針孔成一直線。(圖 28)

When the Needle Bar goes down to the lowest position, the line A of the Rear Needle Guard should be at the center of needles holes. (Fig. 28)

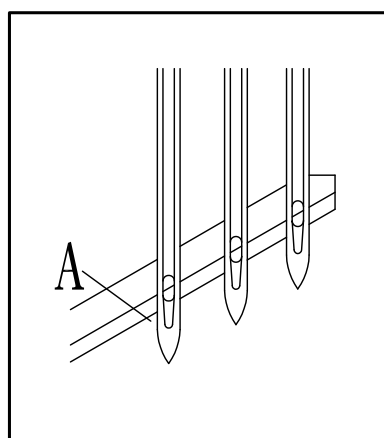

(Fig. 28)

2. 若欲調整頂針片的高度，請放鬆螺絲 (B)、(C) 調整之，但切勿調得太高，以免撞及送料具。(圖 29)

Loosen screw B and C for above adjustment.

Caution : Never adjust the Needle Guard too high to contact Feeding Device. (Fig. 29).

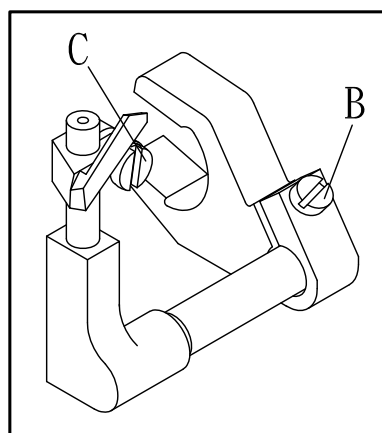

(Fig. 29)

E. 前後頂針片之調整:

ADJUSTING FRONT AND REAR NEEDLE GUARD :

1. 當勾針針尖向左前進，針尖到達右針中心時，此時後頂針片與右針之距離為 0~0.05 mm。而當勾針針尖到達左針中心時，後頂針片與左針之距離亦為 0~0.05 mm。(圖 30)

When Loper tip comes near to the center of Right Needle, make a clearance between Right Needle and Loper 0~0.05mm by actuating Needle Guard (rear), and adjust a clearance between Left Needle and Guard (rear) 0~0.05mm. (Fig. 30)

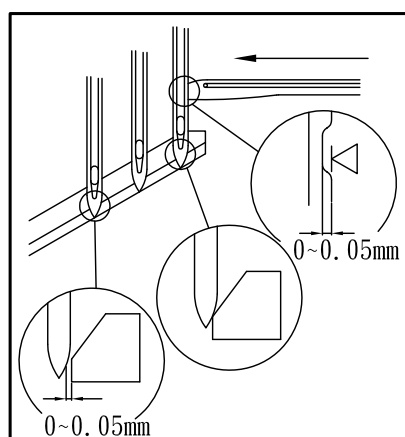

(Fig. 30)

2. 當勾針針尖向前進，針尖到達左針中心點時，前頂針片約高於右針 1.5mm~2.0mm (圖 31)，且左針與前頂針片的距離為 0~0.3mm，當勾針針尖退後針尖到達右針中心點時，前頂針片與右針之距離為 0~0.3mm。(圖 32)

When Loper tip shifts to the center of Left Needle, set the Front Needle Guard 1.5mm ~2.0mm higher than the Left Needle tip. The clearance is 0~0.3mm between Left Needle, Right Needle and Front Needle Guard.

(Fig. 31 & Fig. 32)

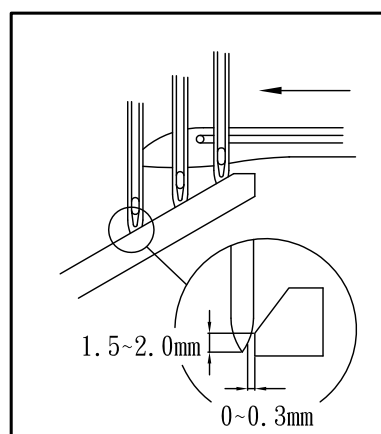

(Fig. 31)

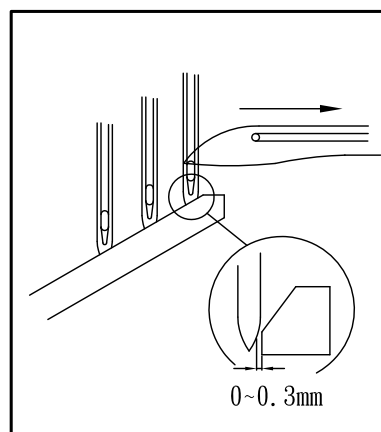

(Fig. 32)

F. 送布齒高度調整:

ADJUSTING THE HEIGHT OF FEED DOG :

1. 當送布齒在最高位置時，送布齒齒尖面與針板面平行，此時主送布齒 A 與差動送布齒 B 高度相同且齒面與針版面差 1.2 ~ 1.5mm 。

When Feed Dog are at the highest position, the surface of Feed Dog and the surface of Stitch Plate becomes parallel with each other.

At this time, make differential feed dog (A) and main feed dog (B) to be at the same height and adjust the distance from surface of Stitch Plate to the surface of Feed Dog to be 1.2~1.5mm. (Fig. 33)

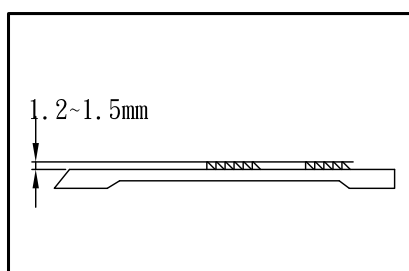

(Fig. 33)

G. 上叉位置的設定:

ADJUSTING THE POSITION OF THE SPREADER :

1. 當勾線針 (A) 向左游走時，其上 (a) 點之位置與最左車針間之間隙應為 0.5mm ~ 0.8mm，且當勾線針 (A) 游走至最左位置時，其上 (a) 點與最左邊車針之間隙一定得在 4.5mm 至 5.5mm 之間。

When Spreader (A) moves from right to left, provide a clearance of 0.5~0.8mm. between Left Needle and the tip (a) of thread hooking point, and when it comes to the extreme left, the clearance between the center of Left Needle and tip (a) of thread hooking point must be 4.5~5.5mm. (Fig. 34)

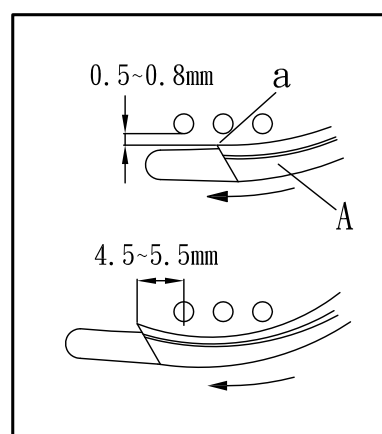

(Fig. 34)

2. 勾線針下緣之高度應保持在針板面之上 9 ~ 11mm 。

Adjust the height of undersurface of Spreader (A) above the top surface of Stitch Plate to be 9~11mm. (Fig. 35)

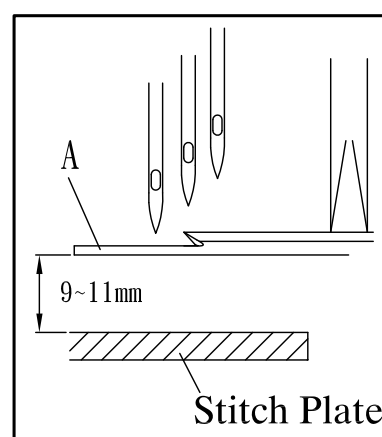

(Fig. 35)

3. 上述之調整動作可藉由放鬆螺絲 (B) 與 (C) 來取得。

Above adjustment is made by loosening Screw (B) of Spreader and Screw (C) of Spreader Holder. (Fig. 36)

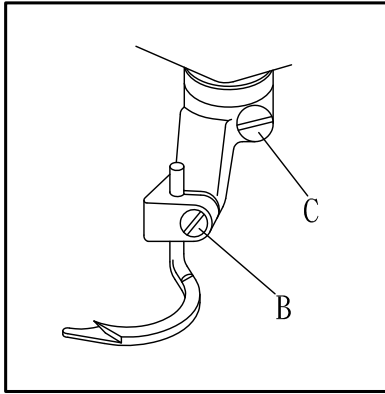

(Fig. 36)

4. 根據所使用之線的不同，必須將車針其勾線針的間隙作以上正確之調整。

The above adjustments should be made properly according to the thread to be used.

H. 上飾線之導線器的固定:

FIXING OF TOP COVER THREAD GUIDE & TOP COVER THREAD EYELET:

1. 當勾線針退至最右位置而能平穩的勾住線時，上飾線之導線器 (D) 的下緣與彎針 (A) 的上緣之間的間隙應為 0.5mm。

調整完畢後，鎖緊螺絲 (E)。(圖37)

Provide a clearance of 0.5mm. between undersurface to Top Cover Thread Guide (D) and the top surface of Spreader (A).

At the position, the thread is caught smoothly by thread hooking part when spreader comes to extreme right, tighten screw (E).

(Fig. 37)

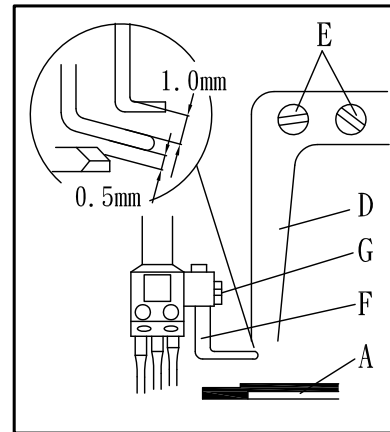

(Fig. 37)

2. 上飾線導線器 (D) 之上緣與上飾線穿線孔器 (F) 之下緣間之間隙應為1.0mm；同時穿線孔器 (F) 之線孔應與導線器 (D) 之長形孔延伸部份在一直線上。調整完畢後，鎖緊螺絲 (G)。(圖 38)

Provide a clearance of 1.0mm. between top surface of Top Cover Thread Guide (D) and undersurface of Top Cover Thread Eyelet (F). (Fig. 37)

Set the hole of Top Cover Thread Eyelet on the extension line of slot of Top Cover Thread Guide, then tighten screw (G). (Fig. 38)

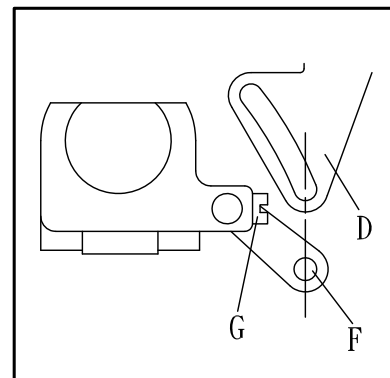

(Fig. 38)

※ 根據所使用之線的不同，而必須將上飾線導線器，穿孔器位置作以上正確之調整。

※ The above (1), (2) should be adjusted properly according as the thread to be used.

I. 勾針控制線桿的位置

THE POSITION OF LOOPER THREAD TAKE-UP:

1. (圖 40) 是從操作員右側觀察勾針控線凸輪 (Fig. 40) is viewed from left side of operator.
2. 當針從最高處下降時，左針大約位於勾針後面之一半的位置時 (圖39) 勾針針線必須脫離凸輪之最高位置 (P)。(圖 40)

When Needle comes down from the highest position and the Left Needle tip sticks around 1/2 position of the looper, (Fig. 39)

The looper thread should come over the highest position P of the Cam. (Fig. 40)

J. 安全開關調整

ADJUSTING SAFETY SWITCH:

(圖41)當每次切線作成時定位感測開關應回到正確相對位置。如定位不足及髒污機器不能運轉。

調整前請先將馬達關閉 A. 調整切刀氣缸最適合的行程是16mm。把軸環 ① 上的螺絲 ② 鬆開。

當氣缸的行程被改變.重新調整切線機構時須檢查調整微動開關。

調整如下:

- (1) 鬆開螺絲 ③ 和 ④。
- (2) 當下切刀回到原點的位置時把微動開關打開到 ON。
- (3) 鎖緊螺絲 ③ 和 ④。

ALWAYS turn OFF the motor switch and check that the motor stops before adjustment.

A. Adjusting trimming air cylinder.

The proper stroke is 16 mm.

For adjustment,loosen the screws ② of the collar ①.

When the stroke of the air cylinder is changed, readjust the action of the thread trimming mechanism.Check that the condition of the detector switch.

When the stroke of the air cylinder is changed, readjust the action of the thread trimming mechanism.Check that the condition of the detector switch.

For adjustment:

- (1)Loosen the screws ③ and ④.
- (2)Adjust so that the switch is turned ON when the trimming knife returns to the original position.
- (3)Tighten the screws ③ and ④.

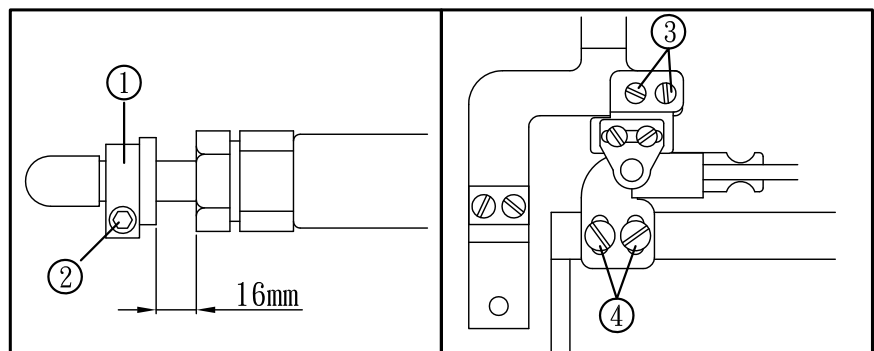
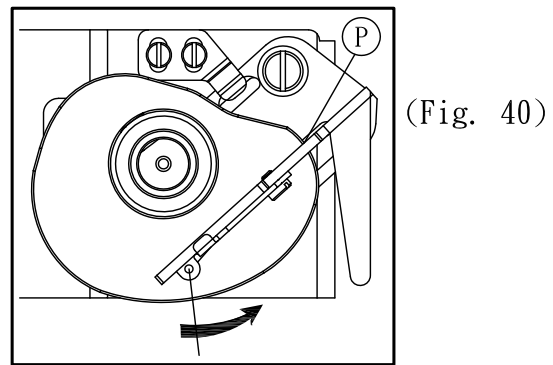
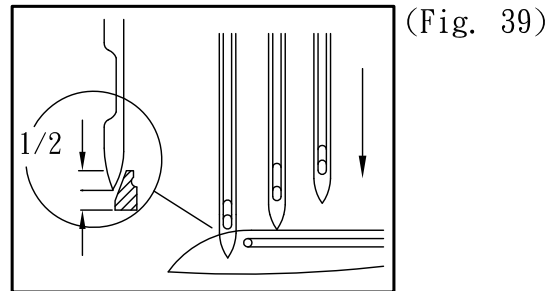

Maker	A	B	C	D
Panasonic	57	159	66.5	33.25
Mitsubishi	60	150	65	32.5
Hitachi	54	159	66.5	33.25
Wang sing	70	120	70	35

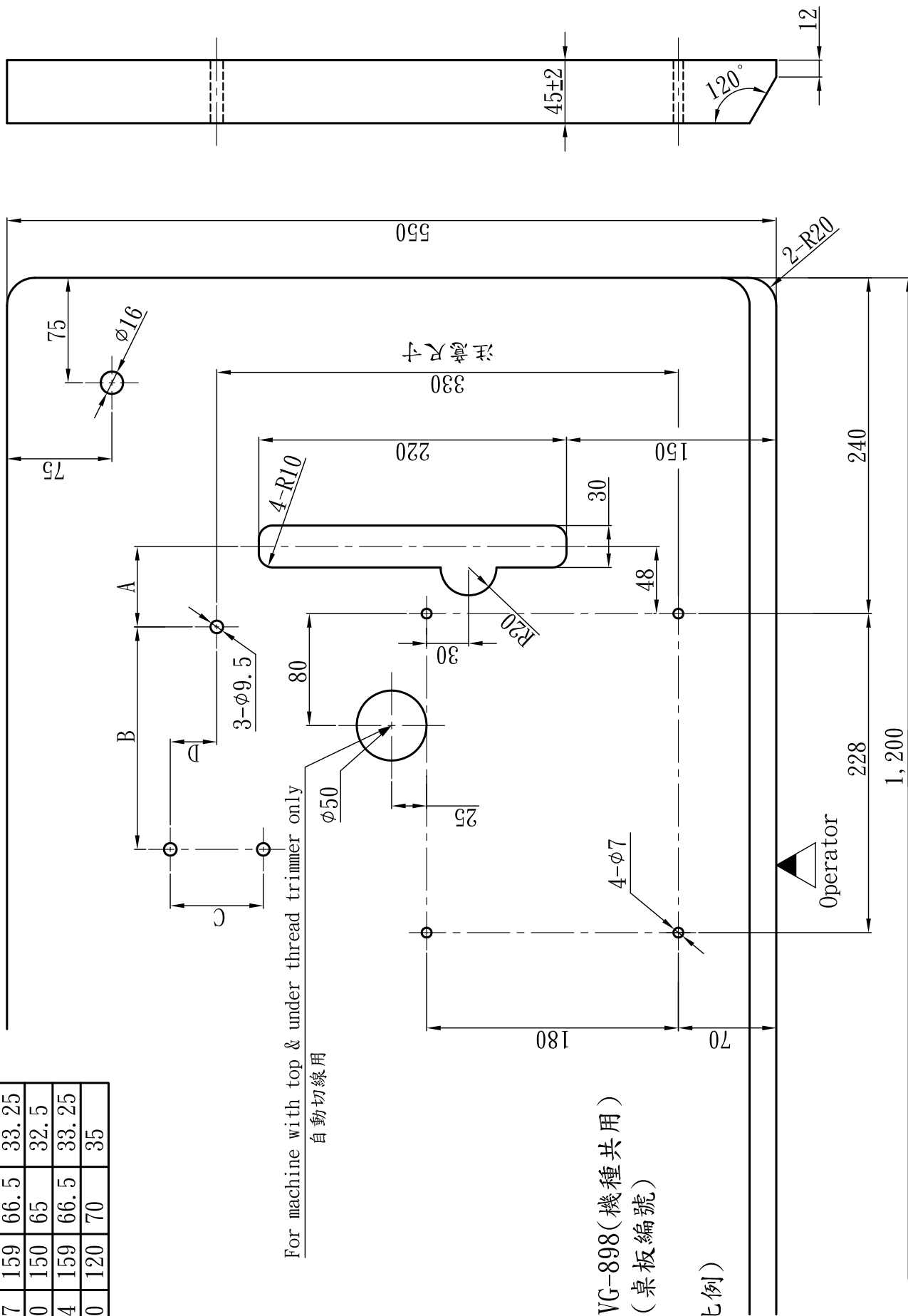

Model: VG-888, VG-898 (機種共用)
Table No: F002 (桌板編號)
Unit: mm (單位)
Scale: 1 / 4 (比例)

INDEX

索引

		PAGE/頁
ADJUSTMENT GUIDE	切線裝置:調整說明	
AIR PIPING DIAGRAM (AST DEVICE)	管路圖 (上下切裝置)	1
AIR PIPING DIAGRAM (AWT DEVICE)	管路圖 (下切裝置)	2
A 、 ADJUSTING TRIMMING AIR CYLINDER	A 、 調整切刀氣缸	3
B 、 POSITION OF LOWER KNIFE	B 、 下切刀位置	4
C 、 RELATION BETWEEN UPPER KNIFE AND LOWER KNIFE	C 、 固定刀與可動力的關係	
D 、 POSITION OF THREAD CLAMP SPRING AND THREAD CLAMP SPRING PRESSURE	D 、 夾線彈片與壓力彈片的位置	5
E 、 PRESSURE OF THREAD CLAMP SPRING	E 、 夾線彈片的壓力	
F 、 POSITION OF UPPER KNIFE CARRIER	F 、 固定刀帶動座的位置	6
G 、 RELATION BETWEEN LOWER KNIFE AND NEEDLE	G 、 活動刀與針的關係	7
H 、 POSITION OF LOWER KNIFE POINT	H 、 活動刀尖點的位置	8
I 、 ADJUSTING LOWER KNIFE CARRIER GUIDE	I 、 調整活動刀帶動引導器	9
J 、 ADJUSTING LOWER KNIFE CARRIER GUIDE (UPPER)	J 、 調整活動刀輔助穩定器 (上面)	10
K 、 RELATION BETWEEN NEEDLE THREAD, LOOPER THREAD AND LOWER KNIFE	K 、 針線 , 下勾針線及活動刀之間 的關係	11
L 、 ADJUSTMENT OF AIR WIPER	L 、 調整吹線器	12
M 、 PRESSER FOOT LIFTER MECHANISM	M 、 壓腳機構	13
N 、 POSITION OF WIPER AND NEEDLES	N 、 撥線器與針之間的關係	14
O 、 ADJUSTMENT FOR WIPER AND CLAMP SPRING	O 、 撥線器與夾線彈片的關係	
P 、 THE HEIGHT OF TOP THREAD TRIMMER	P 、 上切刀之高度	15
Q 、 ANGLES OF TOP THREAD TRIMMER	Q 、 上切刀組之角度	
R 、 POSITION AND STROKE OF THE MOVABLE TRIMMING KNIFE AND FIXED TRIMMING KNIFE	R 、 活動刀與固定刀之間的嚙合與 行程	16
S 、 THREAD TENSION ADJUSTMENT	S 、 鬆線器的調節	17

管路圖

Air piping diagram

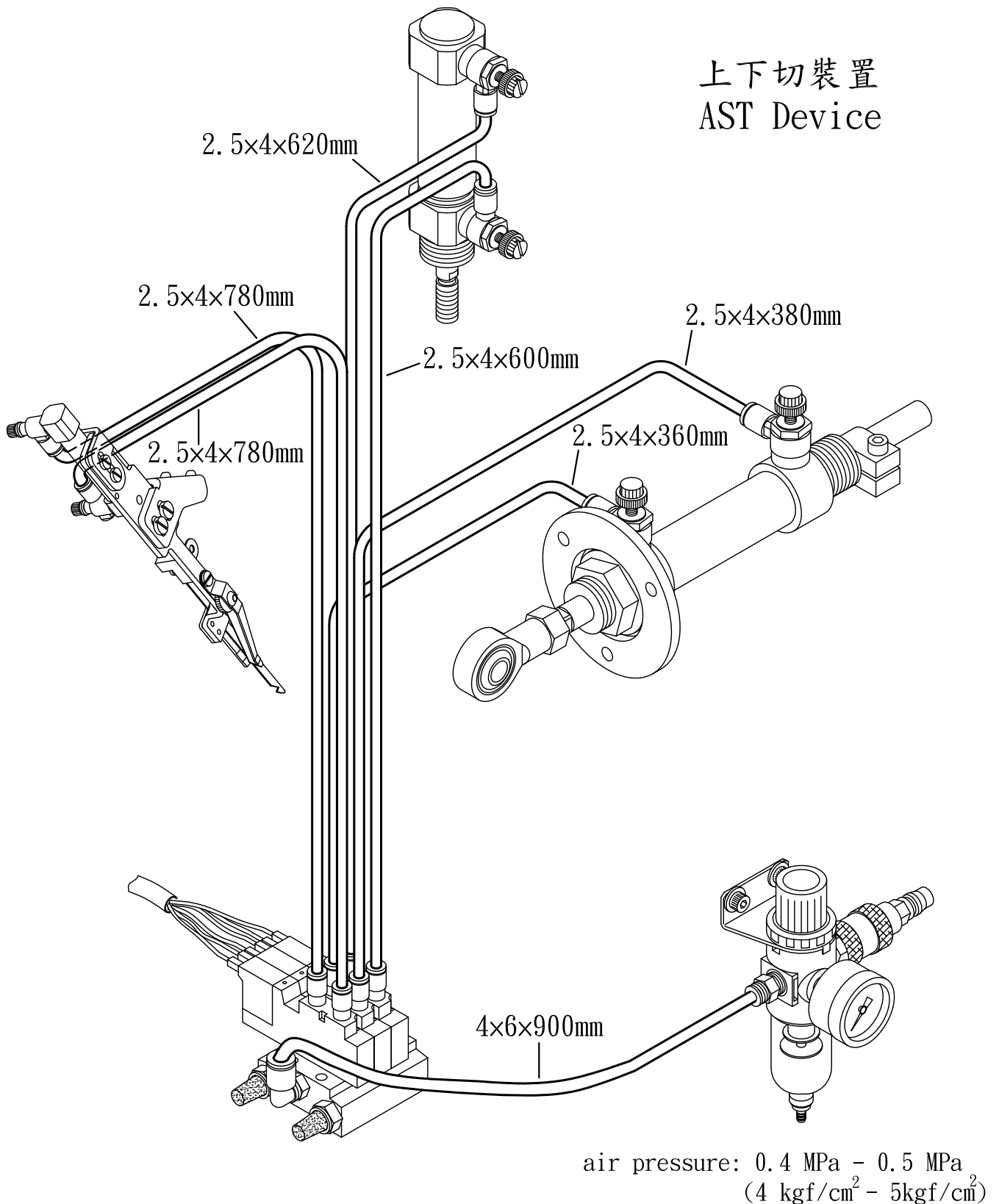

管路圖

Air piping diagram

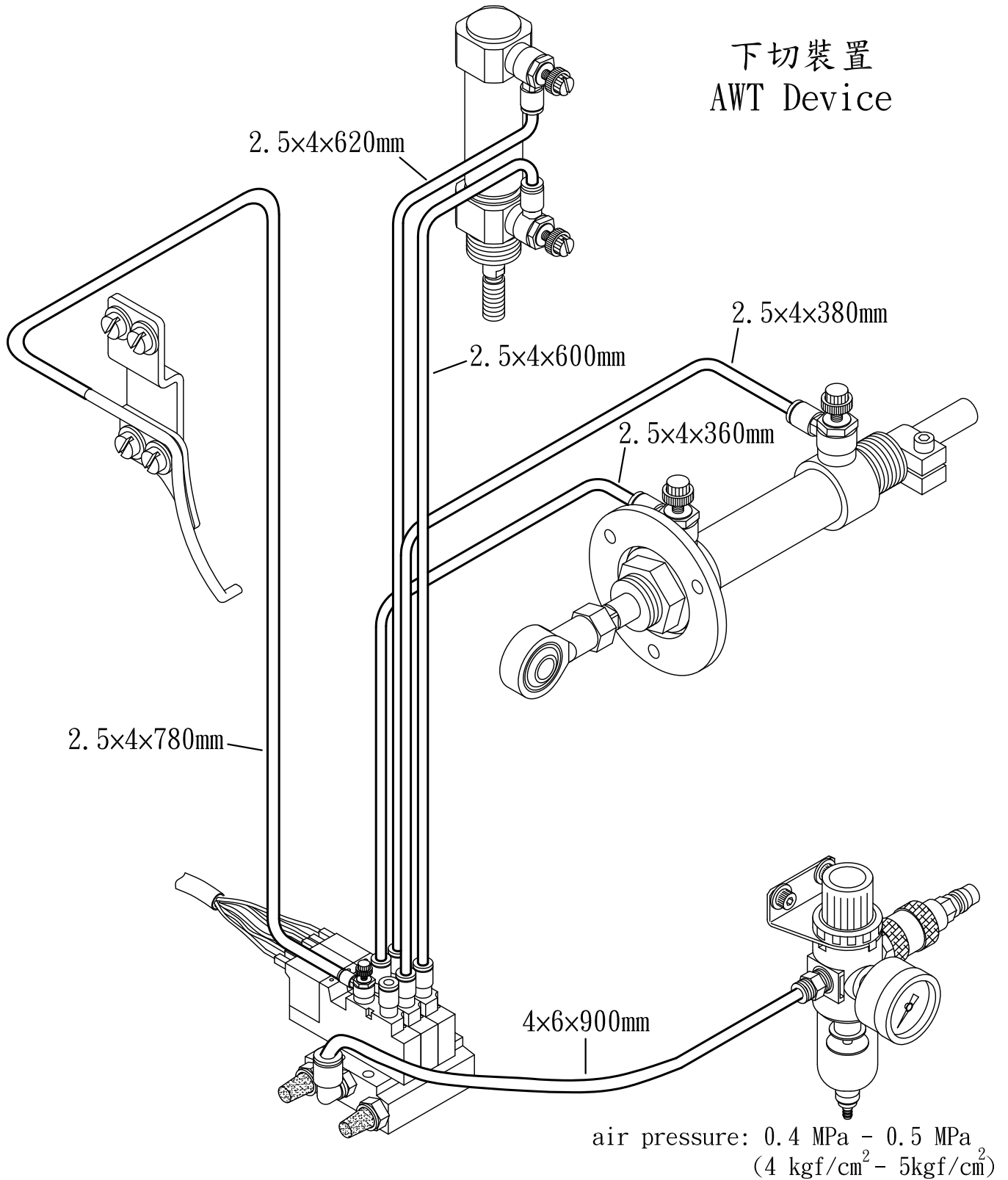

調整說明



警告

調整前請先將馬達關閉

A. 調整切刀氣缸

最適合的行程是 16 mm。

把軸環①上的螺絲②鬆開。



注意

當氣缸的行程被改變，重新調整切線機構時須檢查調整微動開關。

調整如下：

- (1) 鬆開螺絲③和④。
- (2) 當下切刀回到原點的位置時把微動開關打開到 ON。
- (3) 鎖緊螺絲③和④。

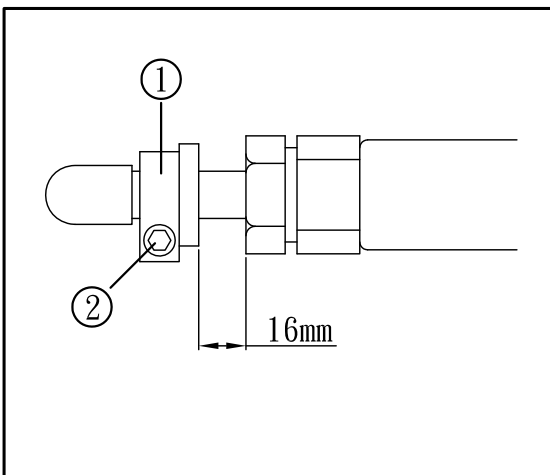

ADJUSTMENT GUIDE



WARNING

ALWAYS turn OFF the motor switch and check that the motor stops before adjustment.

A. Adjusting trimming air cylinder

The proper stroke is 16 mm.

For adjustment, loosen the screws② of the collar①.



NOTE

When the stroke of the air cylinder is changed, readjust the action of the thread trimming mechanism. Check that the condition of the detector switch.

For adjustment :

- (1) Loosen the screws③ and④.
- (2) Adjust so that the switch is turned ON when the trimming knife returns to the original position.
- (3) Tighten the screws③ and④.

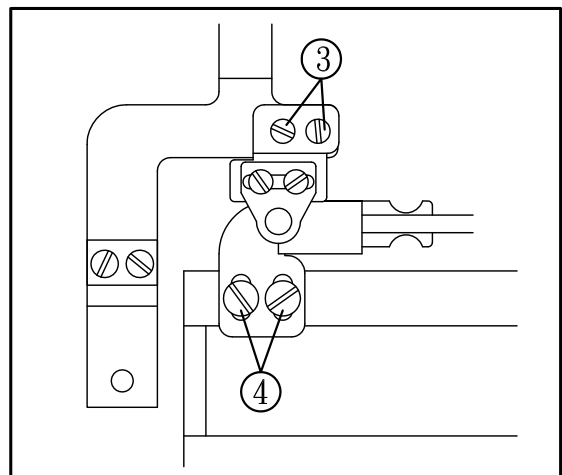

調整說明



警告

調整前請先將馬達關閉

B. 下切刀位置



小心

只有針在最高點時，切刀才可以用手動操作若針不是在最高點，零件可能被碰撞而損傷。

- (1)使可動刀①的邊②和固定刀帶動座③的邊④平行。
- (2)鎖上螺絲⑤。

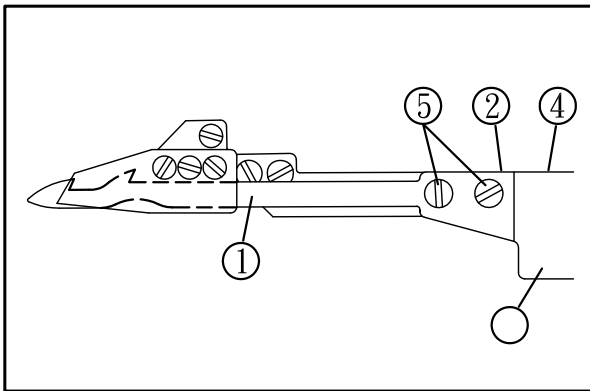

C. 固定刀與可動刀的關係

- (1)放鬆螺絲⑩。
- (2)調整固定刀⑦的尖點⑧與活動刀的尖點⑥對齊。
- (3)當活動刀在止點時左右調整固定刀⑦與活動刀的尖點⑨切0.5mm~1.0mm。
- (4)鎖緊螺絲⑩。

ADJUSTMENT GUIDE



WARNING

ALWAYS turn OFF the motor switch and check that the motor stops before adjustment.

B. Position of lower knife



CAUTION

The trimming knife mechanism can be operated manually only when the needle is at its top.

If the needles are not at the top, the parts may be contacted and broken.

- (1)Make the side②of the lower knife①parallel with the side④of the lower knife carrier③.
- (2)Fix with the screws⑤.

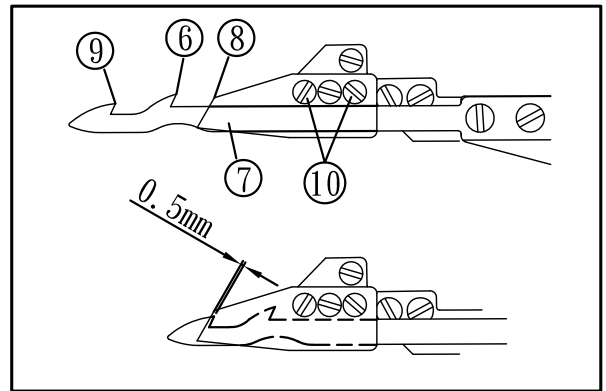

C. Relation between upper knife and lower knife

- (1)Loosen the screws⑩.
- (2)Align the hook⑥for needle thread of the lower knife with the corner⑧of the upper knife⑦.
- (3)When the lower knife is at the extreme right, move the upper knife⑦right and left to make an engagement of 0.5mm~1.0mm between the hook⑨for looper thread and the upper knife⑦.
- (4)Tighten the screws⑩.

調整說明



警告

調整前請先將馬達關閉

D. 夾線彈片與壓力彈片的位置

- (1) 鬆開螺絲 ⑩。
- (2) 調整夾線彈片 ⑪ 與固定刀尖點的距離為 1.5mm。
- (3) 鎖緊螺絲 ⑩。
- (4) 鬆開螺絲 ⑬。
- (5) 調整壓力彈片 ⑫ 與固定刀尖點的距離為 2mm。
- (6) 鎖緊螺絲 ⑬。

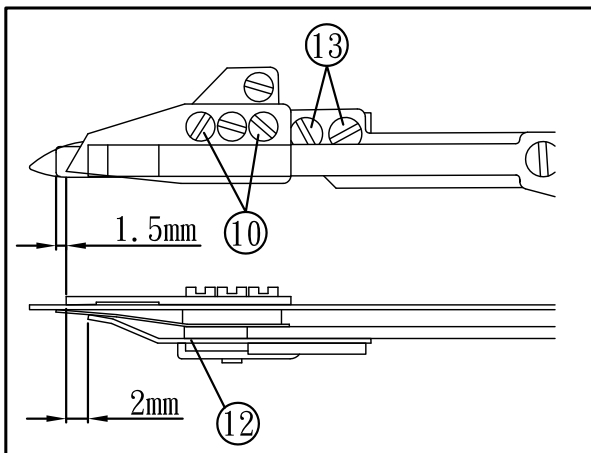

E. 夾線彈片的壓力

- (1) 切線後，下勾針線被夾線彈片 ⑪ 夾住。
- (2) 要增加夾線壓力時，順時針方向轉動 ⑭ 螺絲。
- (3) 要減少夾線壓力時，則為逆時針方向轉動 ⑭ 螺絲。



注意

壓力應該在能夾住下勾針線的範圍即可

ADJUSTMENT GUIDE



WARNING

ALWAYS turn OFF the motor switch and check that the motor stops before adjustment.

D. Position of thread clamp spring and thread clamp spring pressure

- (1) Loosen the screws ⑩.
- (2) Make a distance of 1.5mm from the tip of thread clamp spring ⑪ to that of upper knife.
- (3) Tighten the screws ⑩.
- (4) Loosen the screws ⑬.
- (5) Make a distance of 3mm from the tip of clamp spring pressure to that of upper knife.
- (6) Tighten the screws ⑬.

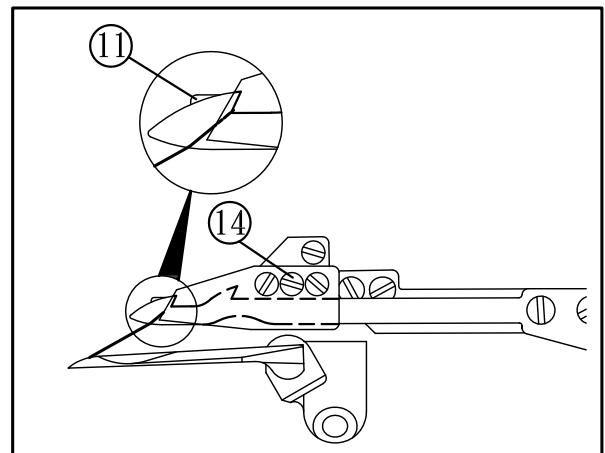

E. Pressure of thread clamp spring

- (1) Looper thread is held by the thread clamp spring ⑪ after cut.
- (2) To increase the pressure, turn the adjusting screw ⑭ clockwise.
- (3) To decrease, turn screw ⑭ counterclockwise.



NOTE

The pressure should be minimized so long as looper thread can be held.

調整說明



警告

調整前請先將馬達關閉

F. 固定刀帶動座的位置

固定刀與活動帶動座③同時滑向左邊，接觸到固定刀帶動器⑬的止動塊⑭後停止，固定刀滑動到針板底下。



小心

帶動座⑬不要滑到太左夾線彈簧會碰撞到下勾針。

調整如下：

- (1) 鬆開螺絲⑱。
- (2) 調整止動塊⑭的位置，其餘螺絲⑱之中心兩邊要對稱。
- (3) 鎖緊螺絲⑱。

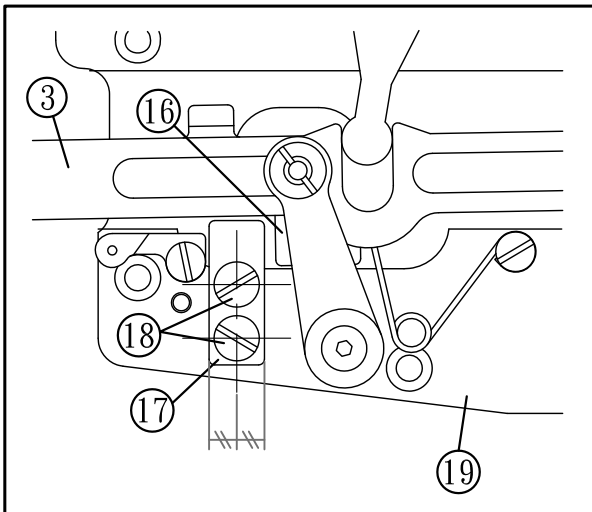

ADJUSTMENT GUIDE



WARNING

ALWAYS turn OFF the motor switch and check that the motor stops before adjustment.

F. Position of upper knife carrier

The upper knife carrier ⑬ slides to the left simultaneously with the lower knife carrier ③ and stops by touching the upper knife carrier stopper ⑭. The upper knife slides under the stitch plate.



CAUTION

NEVER slide the carrier ⑬ to the left too much, because the thread clamp spring pressure touches the looper.

For adjustment :

- (1) Loosen the screws ⑱.
- (2) Adjust screw ⑭ and ⑱ to align with carrier stopper.
- (3) Tighten the screws ⑱.

調整說明



警告

調整前請先將馬達關閉

ADJUSTMENT GUIDE



WARNING

ALWAYS turn OFF the motor switch and check that the motor stops before adjustment.

G. 活動刀與針的關係

- (1) 鬆開螺母 ⑳。
- (2) 把活動刀移到左死點。
- (3) 左右調整連動塊 ㉑ 使活動刀刀口尖點 ⑥ 和左針中心點距離為 2mm ~ 3mm。
- (4) 鬆開螺母 ⑳。

G. Relation between lower knife and needle

- (1) Loosen the nuts ⑳.
- (2) Move the lower knife to the extreme left.
- (3) Adjust the connecting block ㉑ to the right and left to make a distance of 2mm~3mm from the hook ⑥ for needle thread to the left needle.
- (4) Tighten the nuts ⑳.

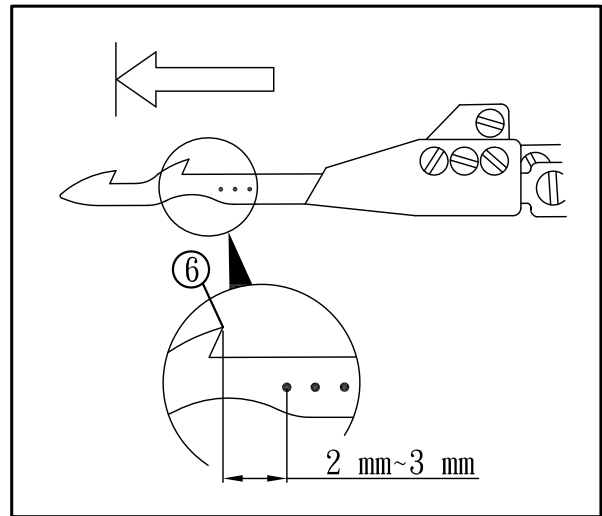
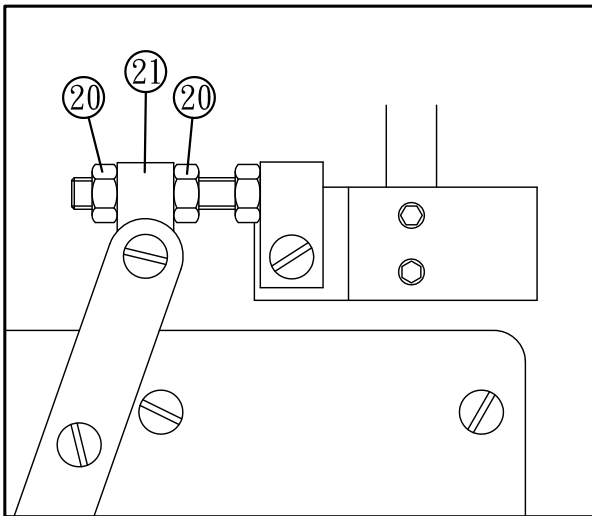

調整說明



警告

調整前請先將馬達關閉

H. 活動刀尖點的位置

- (1) 滑動活動刀到左邊。
- (2) 當活動刀 ① 的點尖點 ② 與下勾針的最右點距離為 12mm，調整活動刀的頂尖點 ② 與下勾針上緣內側 1/3 對齊。
- (3) 鬆開螺絲 ②③ 調整導塊 ②④ 向上可使活動刀頂尖點 ②② 向下移，向下可使活動刀頂尖點 ②② 向上移。
- (4) 鎖緊螺絲 ②③ 。

注意：調整導塊 ②④，其偏心記號 ②A 位置在出廠時，設定在三點鐘方向。

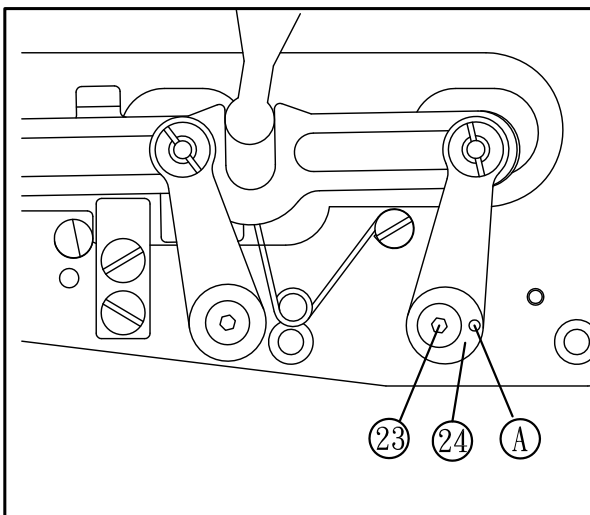

ADJUSTMENT GUIDE



WARNING

ALWAYS turn OFF the motor switch and check that the motor stops before adjustment.

H. Position of lower knife point

- (1) Slide the lower knife to the left.
- (2) When the distance between the point ②② of the knife ① and the right end of the looper is 12mm, center the point ②② on the top of the looper.
- (3) Loosen the screw ②③, adjust guide block ②④ upward ②② to make lower knife point's movement rearward, adjust guide block downward to make its movement forward.
- (4) Tighten the screw ②③.

Note :The mark ②A on guide block ②④ is adjusted at three-o'clock direction before shipment.

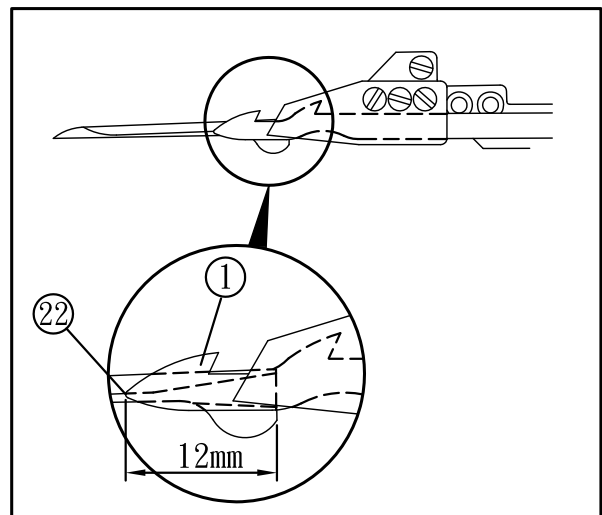

調整說明



警告

調整前請先將馬達關閉

I. 調整活動刀帶動引導器

活動刀下緣與下勾針上緣的距離應為 0.05~0.1mm 之間。

- (1) 鬆開螺絲 (25) 並且下移動活動刀引導器 (26)，使引導器上緣貼到固定刀帶動座下緣。
- (2) 鎖緊螺絲 (25)。
- (3) 檢查固定刀帶動座和活動刀帶動器，必須能夠滑動順暢。

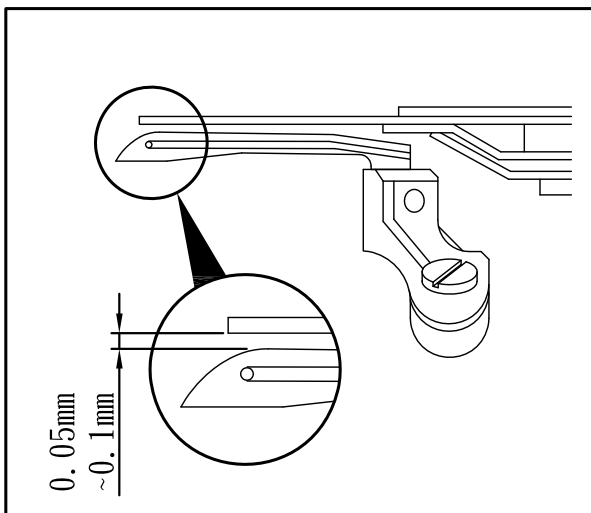

ADJUSTMENT GUIDE



WARNING

ALWAYS turn OFF the motor switch and check that the motor stops before adjustment.

I. Adjusting lower knife carrier guide

The proper distance is 0.05~0.1mm between the lower knife (1) and the top of the looper.

- (1) Loosen the screw (25) and move the lower knife carrier guide (26) up and down to make its top to touch with the bottom of upper knife carrier.
- (2) Tighten the screw (25).
- (3) Check that the upper knife carrier and the lower knife carrier can move smoothly.

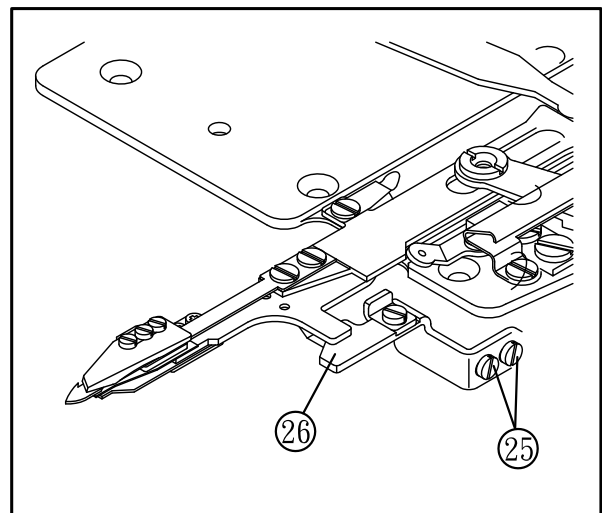

調整說明



警告

調整前請先將馬達關閉

J. 調整活動刀輔助穩定器 (上面)

固定刀帶動座和活動刀帶動座同時滑動到左邊後，接觸固定刀帶動器止動塊後停止。

- (1) 鬆開螺絲 ②⑦。
- (2) 當固定刀帶動器如上所述並停止後，活動刀帶動器 ③ 與活動刀輔助穩定器 ②⑧ 的距離為 0.05~0.1mm。
- (3) 鎖緊螺絲 ②⑦。

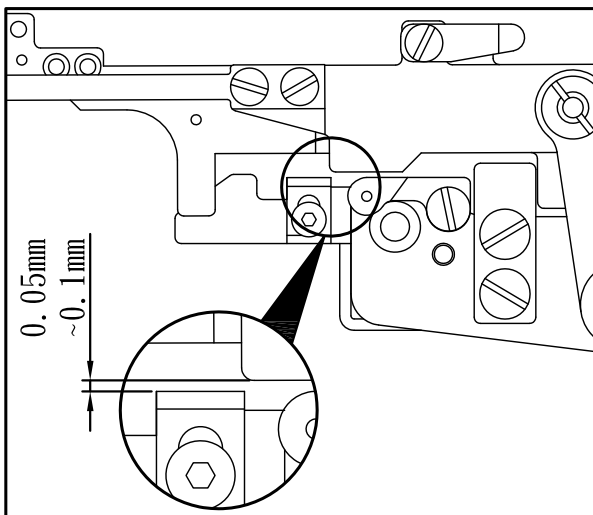

ADJUSTMENT GUIDE



WARNING

ALWAYS turn OFF the motor switch and check that the motor stops before adjustment.

J. Adjusting lower knife carrier guide (upper)

The upper knife carrier slides to the left simultaneously with the lower knife carrier and stops by touching the upper knife carrier stopper.

- (1) Loosen the screws ②⑦.
- (2) When the upper knife carrier is stopped as mentioned above, make a distance of 0.05mm~0.1mm between the lower knife carrier ③ and the lower knife guide (upper) ②⑧.
- (3) Tighten the screw ②⑦.

調整說明



警告

調整前請先將馬達關閉

K. 針線，下勾針線及活動刀之間的關係

車縫前，請檢查如否照以下方式設定：

- 活動刀①通過線圈②⑨和⑩。
- 活動刀口⑨移到下勾線的前面。
- 針線由活動刀口⑥拉到右邊後，被固定刀切斷。
- 下勾針線由活動刀口⑨拉到右邊後，被固定刀切斷。

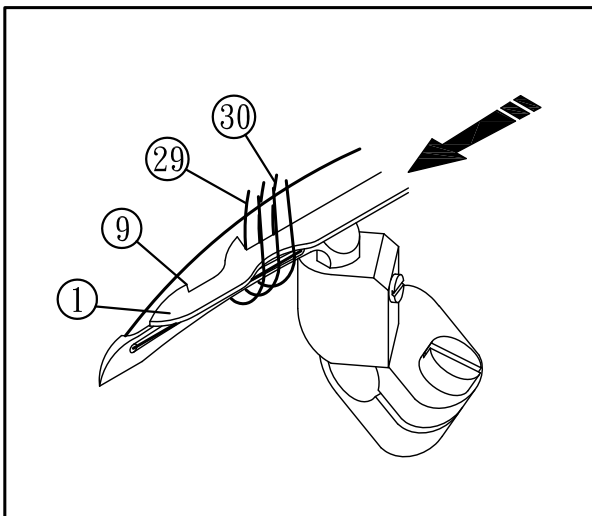

ADJUSTMENT GUIDE



WARNING

ALWAYS turn OFF the motor switch and check that the motor stops before adjustment.

K. Relation between needle thread, looper thread and lower knife

Before sewing performance, be sure to check as follow :

- The lower knife①passes through the loops②⑨ and⑩ of needle thread.
- The hook⑨for looper thread moves in front of looper thread.
- The needle thread is pulled to the right by the hook⑥to be cut by the upper knife.
- The looper thread is pulled to the right by the hook⑨to be cut by the upper knife.

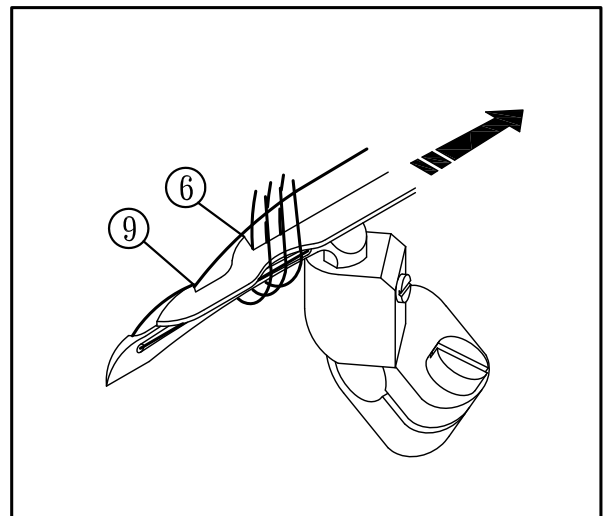

調整說明



警告

調整前請先將馬達關閉

L. 調整吹線器

- (1) 鬆開螺絲 ③。
- (2) 前後調整吹線器使位置在針後面吹氣。
- (3) 鎖緊螺絲 ③。
- (4) 鬆開螺絲 ④。
- (5) 當針提升到最高度，吹線器 ① 的吹孔中心點應在左針針孔下方 1~2mm 處。
- (6) 鎖緊螺絲 ④。
- (7) 從調整扭 ⑤ 調整吹氣流量，要減少吹氣流量，轉順時針方向，要增加則轉逆時針方向。



注意

- (1) 空氣流量儘量極小化。
- (2) 不可從針的前面吹氣，針線可能從針孔脫線。

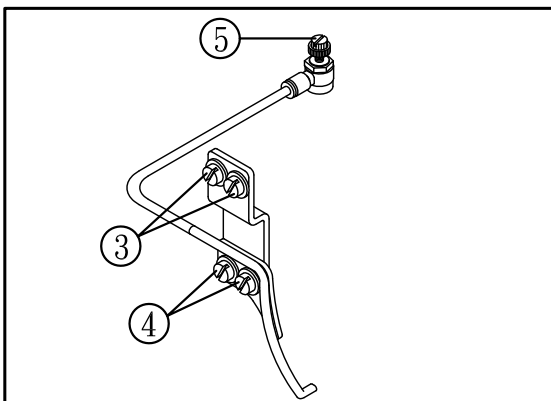
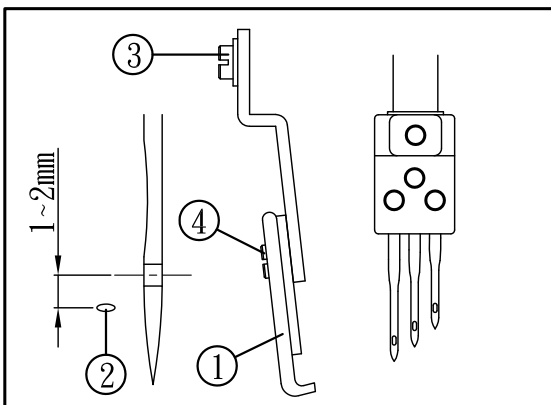

ADJUSTMENT GUIDE



WARNING

ALWAYS turn OFF the motor switch and check that the motor stops before adjustment.

L. Adjustment of air wiper

- (1) Loosen the screws ③.
- (2) Slide the air wiper back and forth to position so that the wiper blows air behind the needle.
- (3) Tighten the screws ③.
- (4) Loosen the screws ④.
- (5) When the needles are at the top of their travel, position the air wiper ① so that the center of the air blowing hole is 1.0mm~2.0mm below the needle eye of the left needle.
- (6) Tighter the screws ④.
- (7) Adjust the air flow with the speed controller ⑤.

To decrease the air flow, turn the adjusting screw clockwise.

To increase, turn counterclockwise.



NOTE

- (1) The air flow should be minimized.
- (2) If air is blow in front of the needles, needle thread may be slipped away from needle eye. Be sure to make it blow behind the needles.

調整說明



警告

調整前請先將馬達關閉

ADJUSTMENT GUIDE



WARNING

ALWAYS turn OFF the motor switch and check that the motor stops before adjustment.

M. 壓腳機構

- (1) 鬆開固定螺母 ②。
- (2) 轉氣缸桿襯片 ③ 調整氣缸移到最下方時，抬壓腳上升 6~7.5mm。
- (3) 鎖緊固定螺母 ②。

M. Presser foot lifter mechanism

- (1) Loosen the lock nut ②.
- (2) Turn the cylinder rod chip ③ and adjust so that the presser foot rises by 6~7.5mm when the cylinder rod is at its bottom (when the cylinder operates).
- (3) Tighten the lock nut ②.

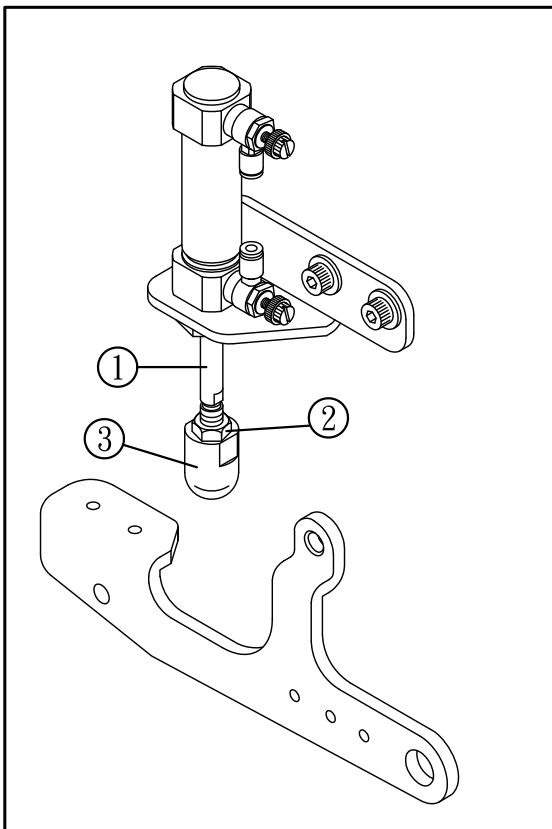

調整說明



警告

調整前請先將馬達關閉

N. 撥線器與針之間的關係

- (1) 撥線勾①往下擺動經過針外徑時，撥線片勾尖②與針外徑③為相切。
- (2) 撥線勾①與最左針之針眼底端的距離為 1.0~1.5mm。
- (3) 當撥線器在左底點時，針棒中心點與撥線勾頂點②距離為 6.0mm。
- (4) 調整時可鬆開螺絲④做上下調整；⑤做前後調整，至適當位置。
- (5) 頂針片⑥與撥線勾距離為 0.2mm。

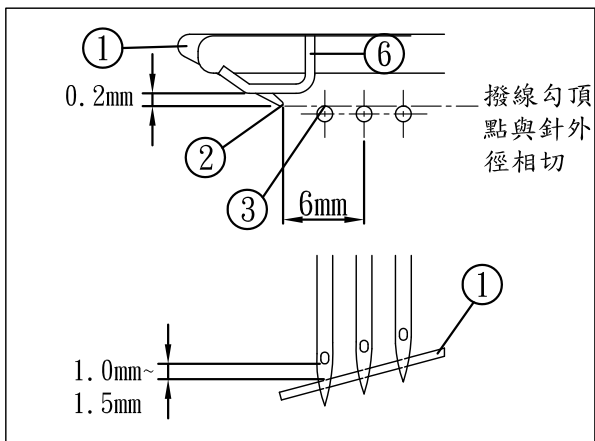

O. 撥線器與夾線彈片的關係

- (1) 調整夾線彈片⑦與撥線勾①能輕輕拉住針線即可。

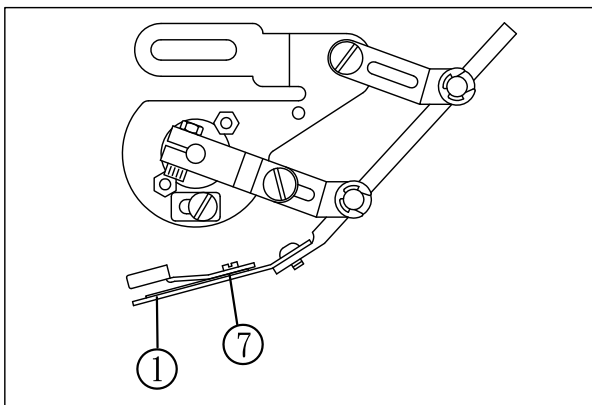

ADJUSTMENT GUIDE



WARNING

ALWAYS turn OFF the motor switch and check that the motor stops before adjustment.

N. Position of wiper and needles

- (1) When wiper① is at down dead point, the clearance between wiper hook② and③needles is 0mm.
- (2) The clearance between wiper①and left needle is 1.0mm.
- (3) The clearance between wiper hook② and middle needle is 6.0mm.
- (4) To adjust the up and down position by loosening the screw④; left and right position by screw⑤.
- (5) The gap between needle guard⑥and the hook tip of wiper is 0.2 mm.

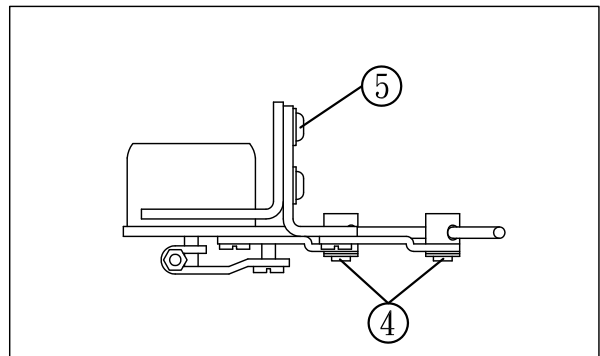

O. Adjustment for wiper and clamp spring

- (1) Adjust the clamp spring⑦and wiper hook①to hold the needle threads gently.

調整說明



警告

調整前請先將馬達關閉

ADJUSTMENT GUIDE



WARNING

ALWAYS turn OFF the motor switch and check that the motor stops before adjustment.

P. 上切刀之高度



小心

安裝、調整上切刀組時須先確定針棒是否停於上定點，且上勾針之相關位置必須於正常狀態下。

- (1)當活動刀片移至最低點時，活動刀之刀尖①與上勾針②之上沿須切齊等高。
- (2)調整時可鬆開螺絲⑦調整切刀之高低。(圖A)(見16頁)

P. The height of top thread trimmer



CAUTION

Please make sure the needle bar is at up dead point, and the spreader's position is normal prior to install and adjust top thread trimmer.

- (1)When movable trimming knife is at down dead point, its hook ① is at the same height of the spreader ②.
- (2)Adjust its height by loosening the screw ⑦. (Fig. A)(Page. 16)

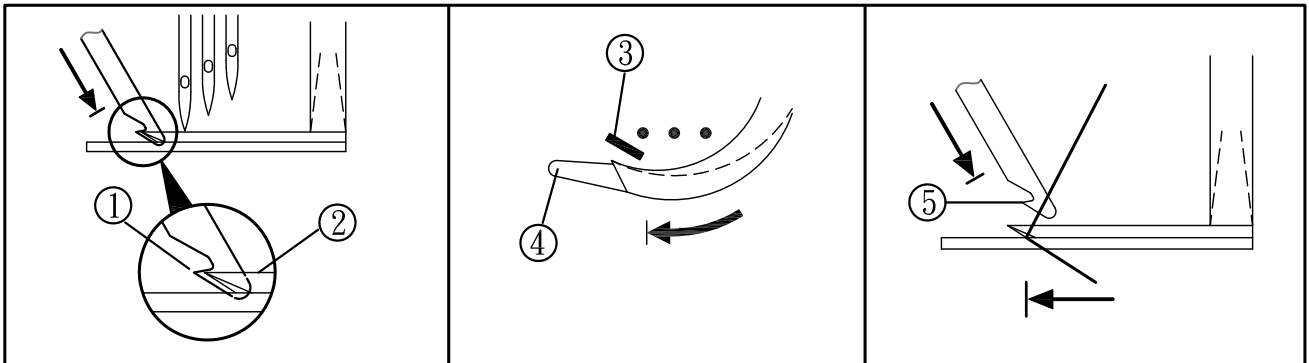

Q. 上切刀組之角度

- (1)當活動刀片③往下移至下定點，須位平針及上勾針④之間隙中央。
注意：活動刀片不可和針磨擦碰撞。
- (2)活動刀片往下移時，刀片前端斜面須和上飾線有磨擦接觸情形⑤，當活動刀片往上收時，上飾線才能順利滑入刀槽內。
- (3)調整時可放鬆螺絲⑧調整切刀之角度。(圖A)(見17頁)

Q. Angles of top thread trimmer

- (1)Movable trimming knife is between needle ① and spreader ② when it is at down dead point.
Note: Movable trimming knife can't touch needle and spreader.
- (2)When movable trimming knife is moving downward, it will touch the spreader lightly ③ to make sure when movable trimming knife moves upward, the upper thread can be trimmed properly.
- (3)Adjust the angles by loosening the screws ⑧. (Fig. A)(Page. 17)

調整說明



警告

調整前請先將馬達關閉

R. 活動刀與固定刀之間的嚙合與行程

- (1)活動刀刀尖①固定刀邊緣要有 0~0.5mm的嚙合。
- (2)活動刀被驅動到最低點時，活動刀刀尖①與固定刀下緣須有 14.5mm 的距離。
<電動式上切刀15~18mm>
- (3)調整時可鬆開螺絲⑩，移動活動座⑨作以上調整。
- (4)切線後，上飾線須被夾線片④與活動刀穩穩夾住。
- (5)調整時可鬆開螺絲⑤，旋轉螺絲⑥，使夾線片至適當鬆緊。

Fig. A

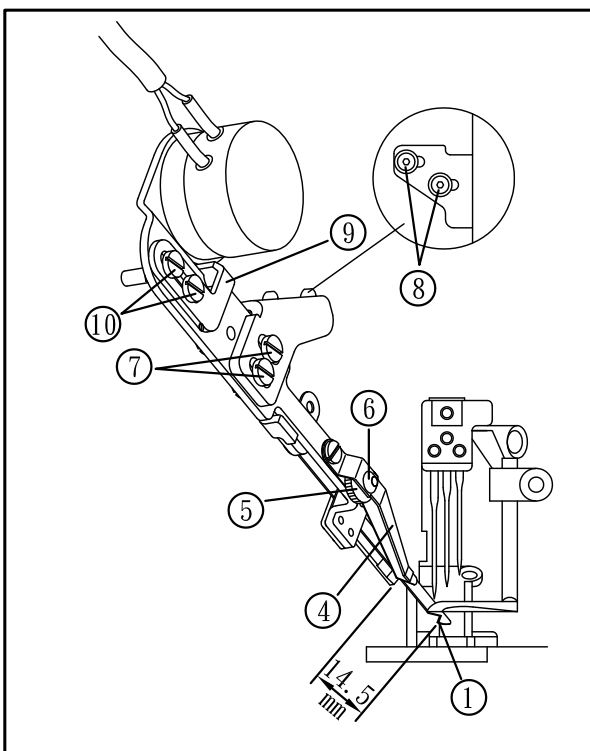

ADJUSTMENT GUIDE



WARNING

ALWAYS turn OFF the motor switch and check that the motor stops before adjustment.

R. Position and stroke of the movable trimming knife and fixed trimming knife

- (1)The clearance between hook①and the edge of fixed knife should be 0~0.5mm
- (2)When movable trimming knife is at its down dead point, the distance between its hook①and the bottom of the fixed trimming knife should be 14.5mm. (15~18mm for electrical type).
- (3)To adjust the movable holder⑨by loosening the screws⑩.
- (4)After trimming, upper thread have to be clipped by clamp spring and movable trimming knife smoothly.
- (5)Adjust the clamp spring to proper tension by loosening screw⑤and turning screw⑥.

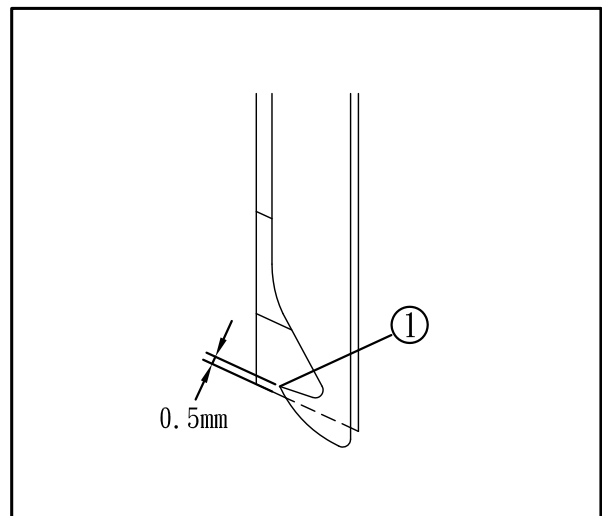

調整說明



警告

調整前請先將馬達關閉

ADJUSTMENT GUIDE



WARNING

ALWAYS turn OFF the motor switch and check that the motor stops before adjustment.

S. 鬆線器的調節

先鬆開螺絲(A)，將鬆線桿與鬆線架調整距離，若使用SP線，建議調節至8mm(如圖中標註所示)，若使用尼龍線等伸縮性較強的線，則建議調節至0mm(圖9)。

S. Thread Tension Adjustment

Please loosen screw A for the following adjustment.

When sewing SP (Cotton)Threads or equivalent, the distance between thread pull-off-hook and the center of ferrule is 8mm. When sewing Nylon or Elastic Threads, the distance between them is around 0mm (Almost align with each other).

After the adjustment, please fasten screw A.

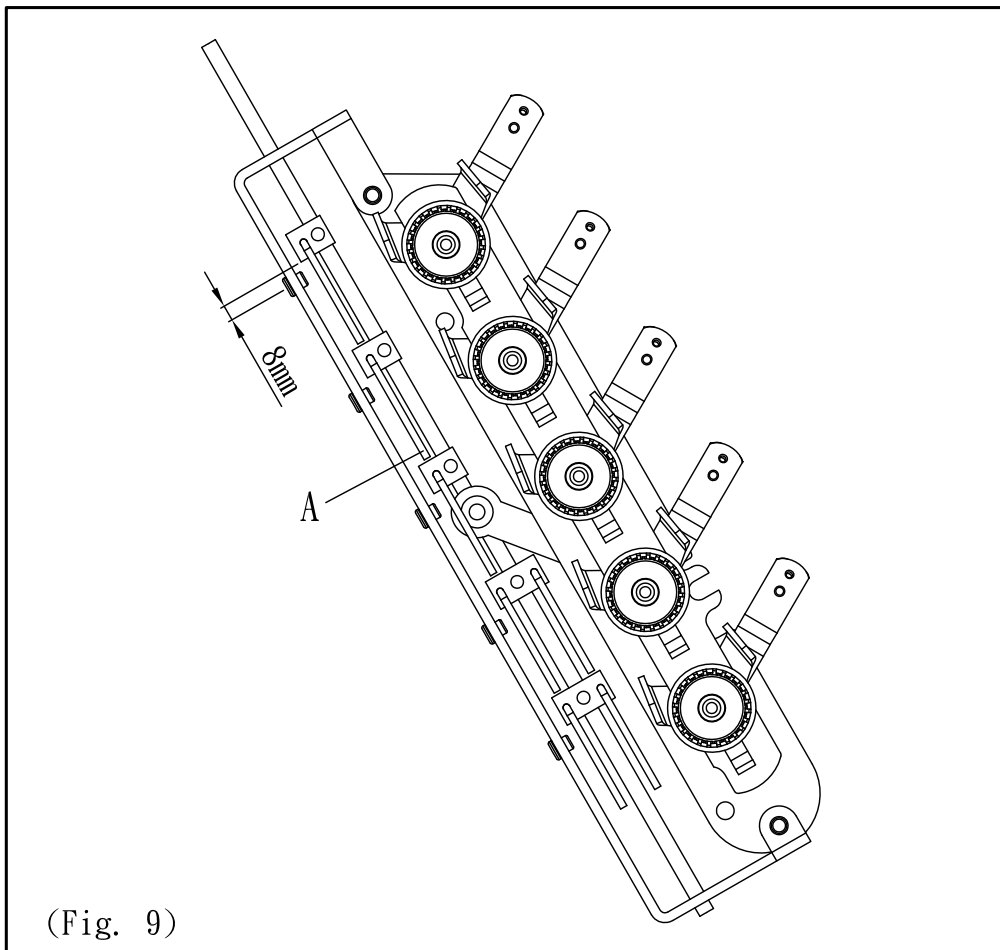



SINCE 1989

SHING LING®

星菱牌工業用縫紉機

INDUSTRIAL SEWING MACHINE



百分之百台灣製造
100% Made in Taiwan



台正字第8144號



TAIWAN
EXCELLENCE 2012

SL-703-GX-452/460/DS/PLA/VD

4-needle 6-thread feed-off-the-arm Interlock Flatseaming Machine with dual differential feed ratio regulator
手臂型四針六線併縫機(附雙差動送布齒裝置)

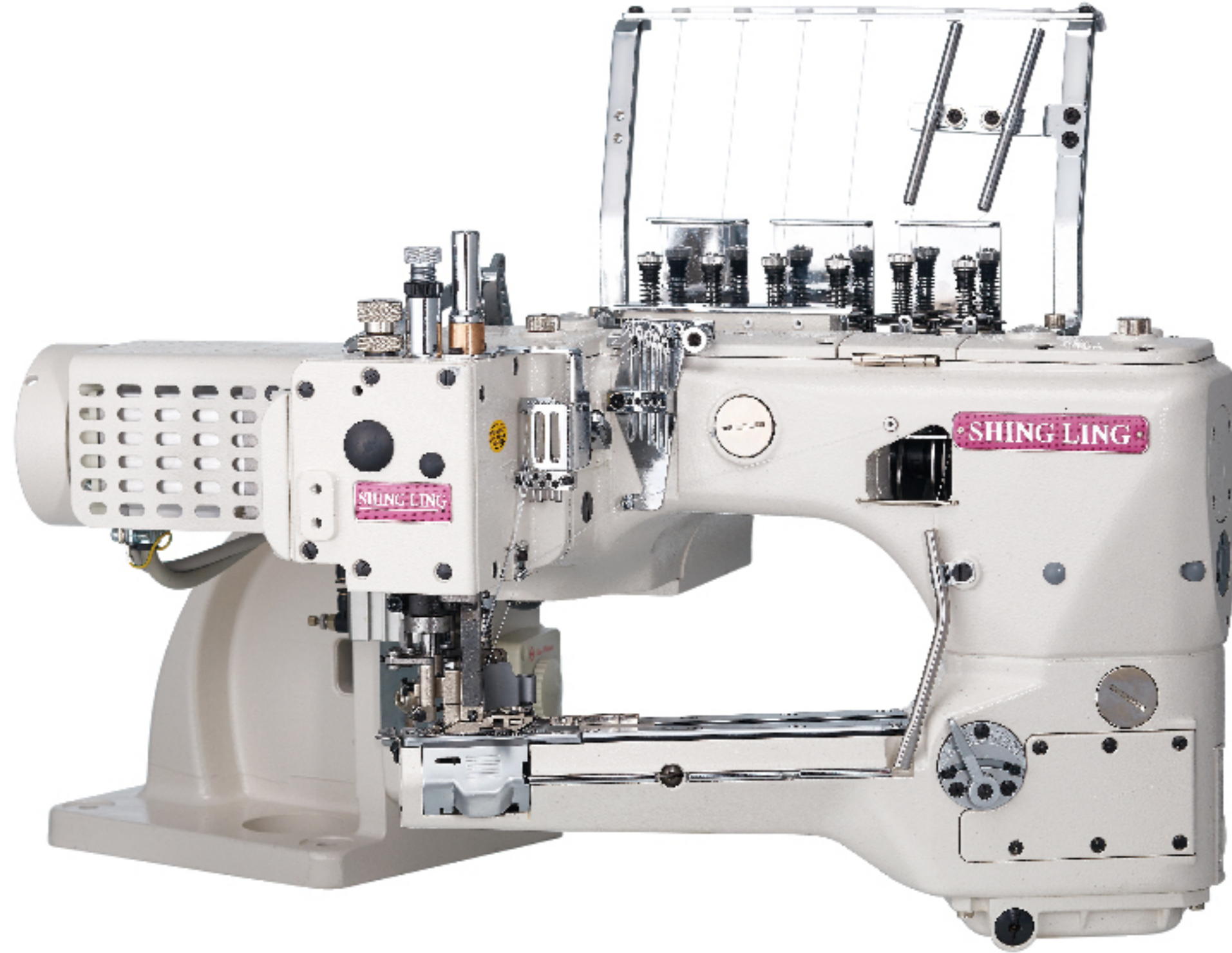

SL-2700-AST/EST

Feed-up-the-arm Interlock Machine with Compact Servo Motor and Thread Trimmer
縱筒型三針五線雙面飾綳縫機



SL-2800-356/SM

Feed-up-the-arm Interlock Machine with Compact Servo Motor and Thread Trimmer
縱筒型三針五線雙面飾綳縫機

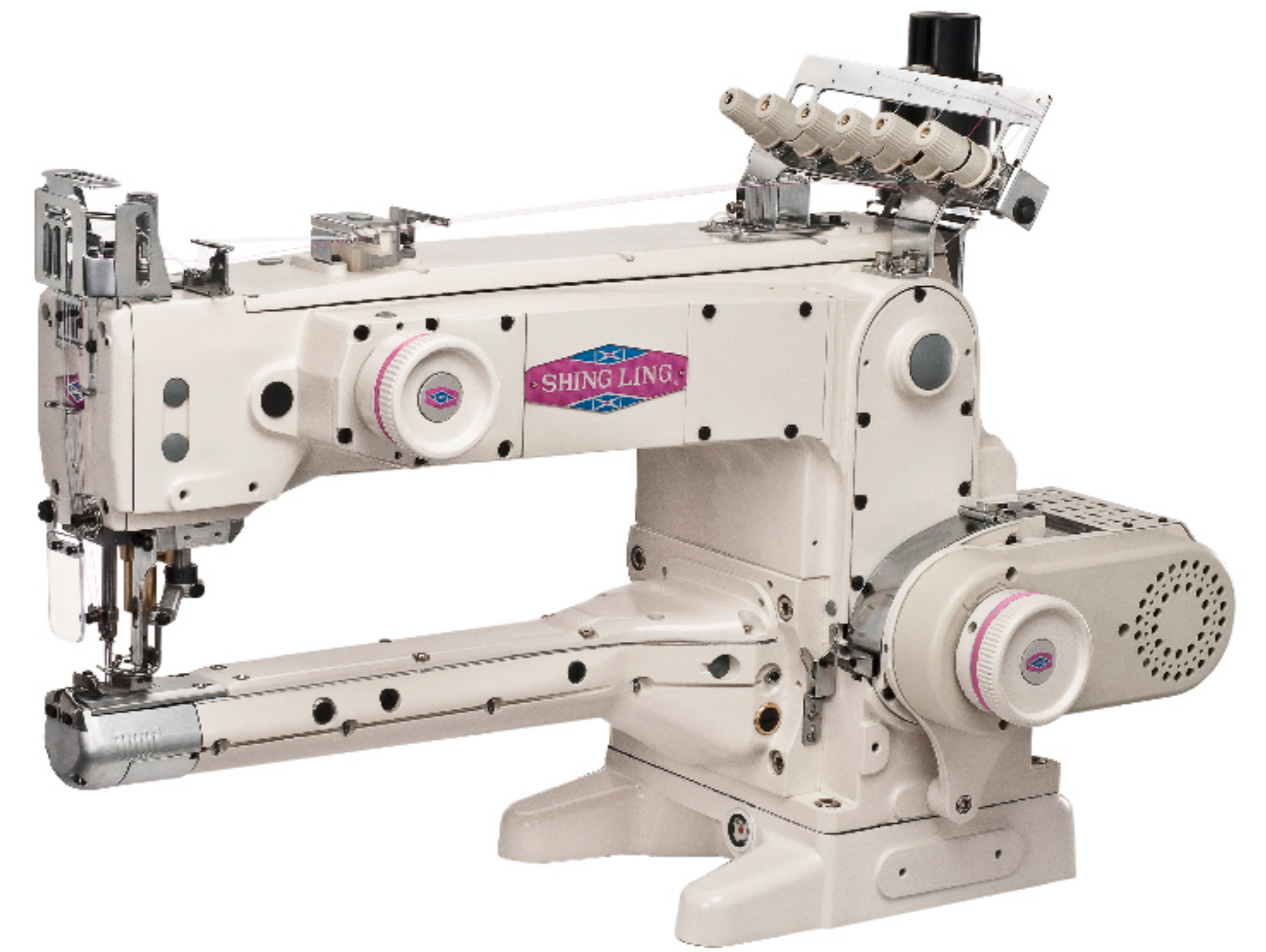

VG-999ES-AST-TF-DS

Extremely-Small Cylinder-bed Interlock Machine with Thread Trimmer and Top Feeder
超細筒型三針五線雙面飾綳縫機



VG-888S-TF-AST

Small Cylinder-bed Interlock Machine with Thread Trimmer and Top Feeder
細筒型三針五線雙面飾綳縫機(附上送裝置)



VG-888A-TF/AST

Top Feeder for 3-needle 5-thread Cylinder-bed Interlock Machine
橫筒型三針五線雙面飾綳縫機(附上送裝置)

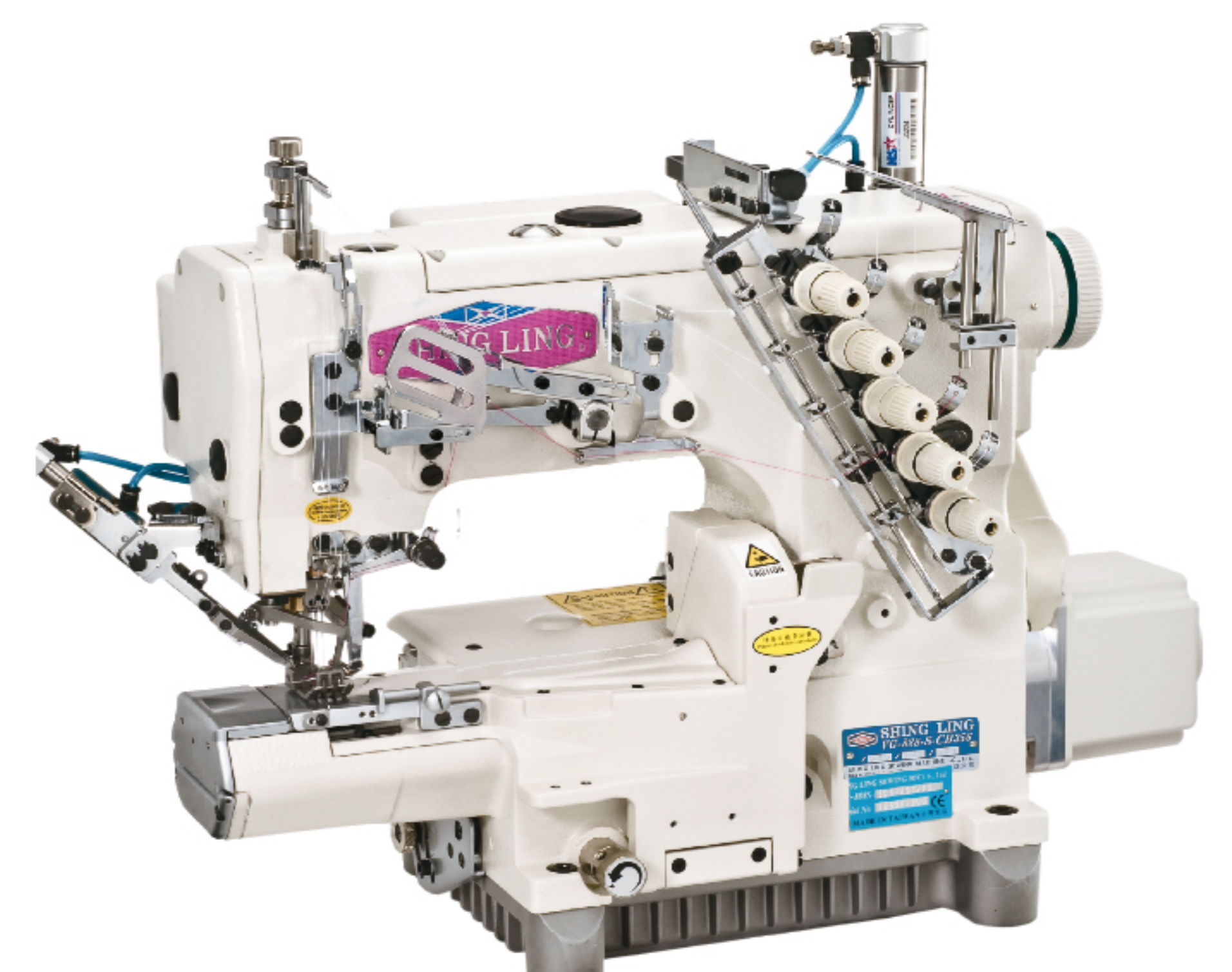

VG-999S-N700-AST-TF-DS

Small Cylinder-bed Interlock Machine with Left hand Knife and Top Feeder for Hemming
細筒型三針五線雙面飾綳縫機(附左修刀)

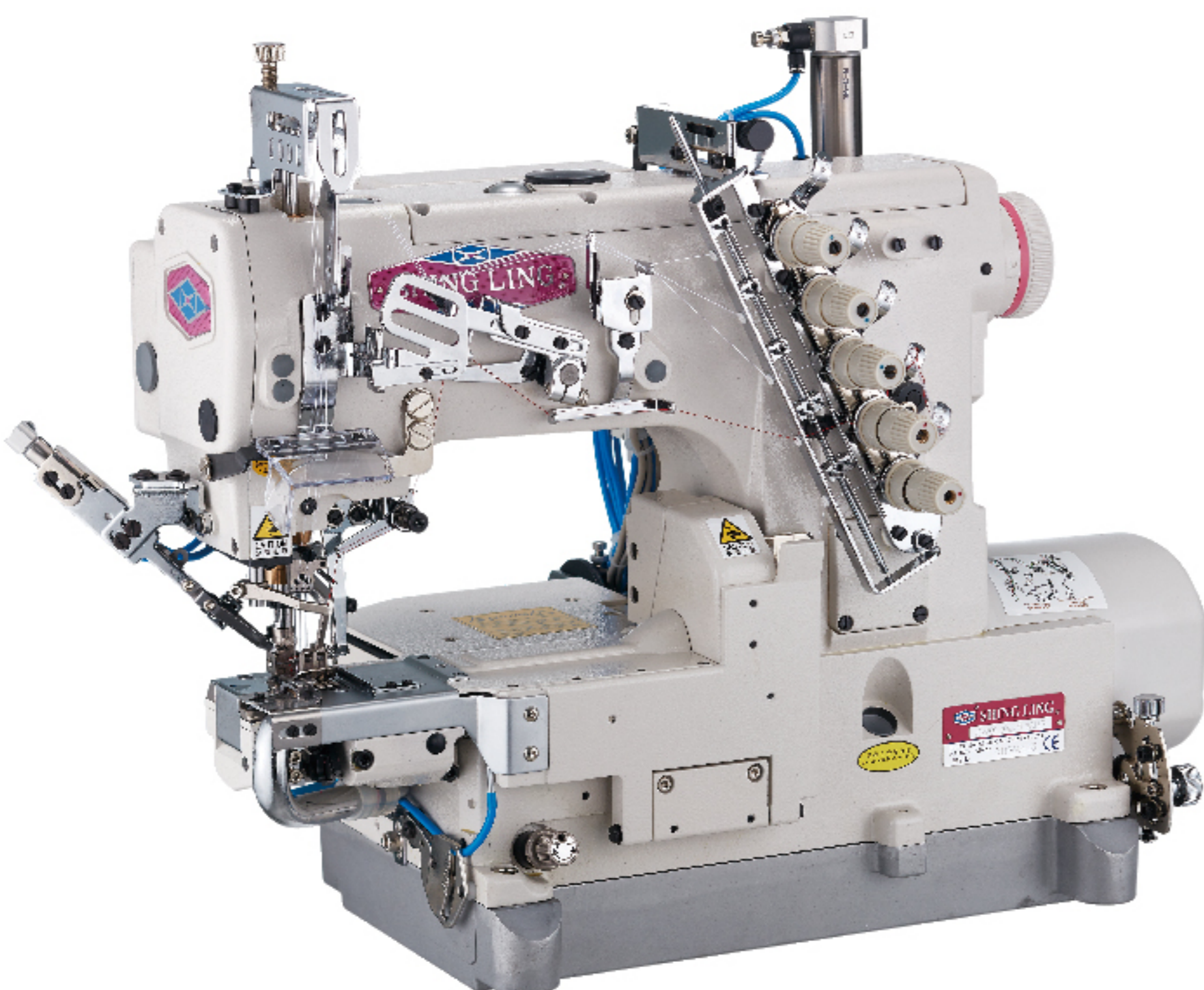

VG-888A-N600-TF/AST

Interlock Machine with Left-hand Knife and Thread Trimmer for Hemming
橫筒型附左修刀雙面飾綳縫機

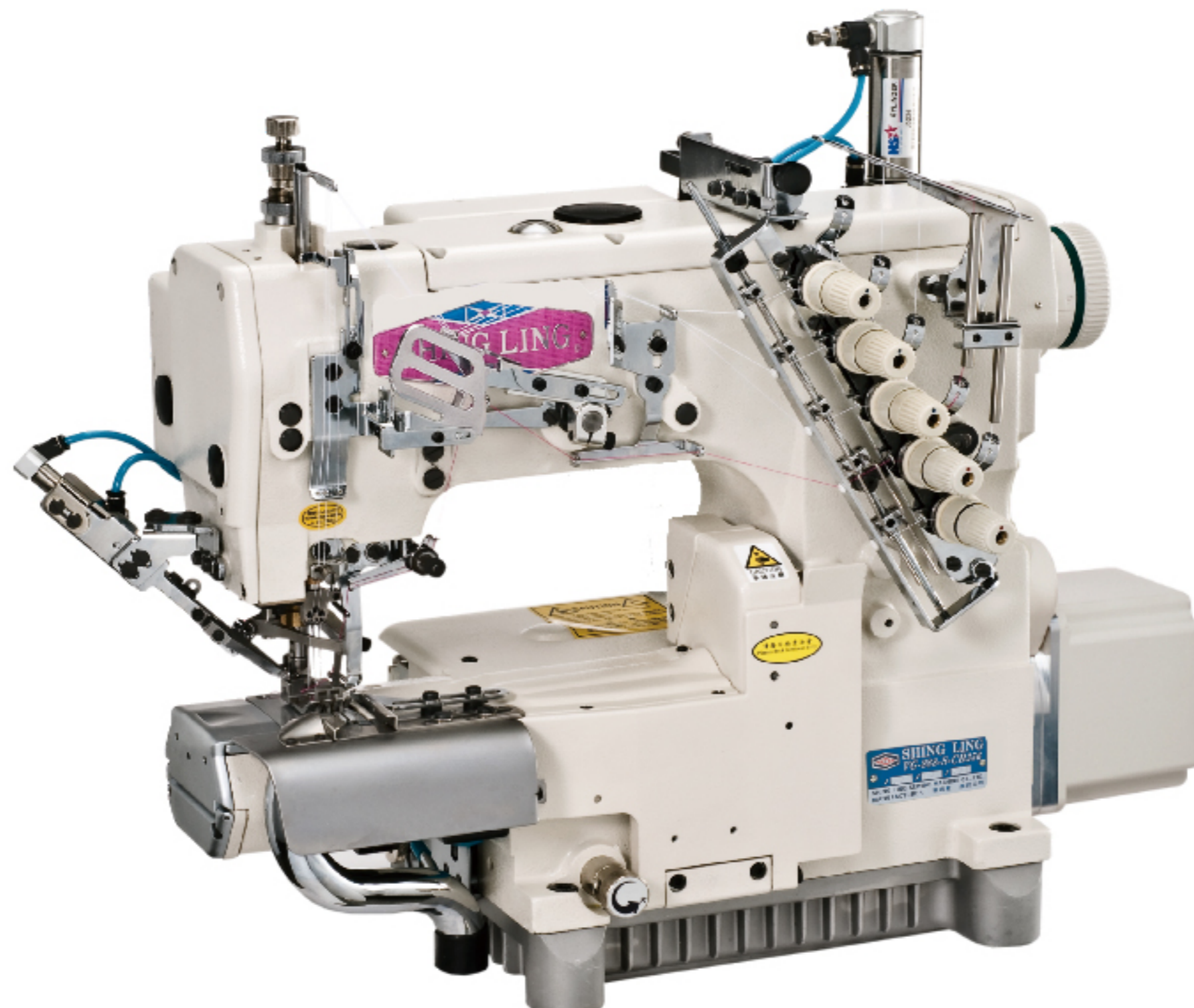

SL-1790S

Computer-controlled High-speed Lockstitch Buttonholing Machine
高速電子平頭鎖眼機



VG-999-SB-AST/EST-DS

High-speed Short Cylinder-bed Interlock Machine with Thread Trimmer
短筒型三針五線雙面飾綳縫機



VG-999-R500-AST-RP

Interlock Machine with Right-hand Knife and Rear Puller for Elastic Waistband Attaching
高速橫筒型三針五線附右修刀雙面飾綳縫機



VG-999-356/EST/DS/ZBR

Dual Colors Decorative Stitches Interlock Machine with Top and Under Thread Trimmer
高速橫筒型三針五線雙色上飾綳縫機

